

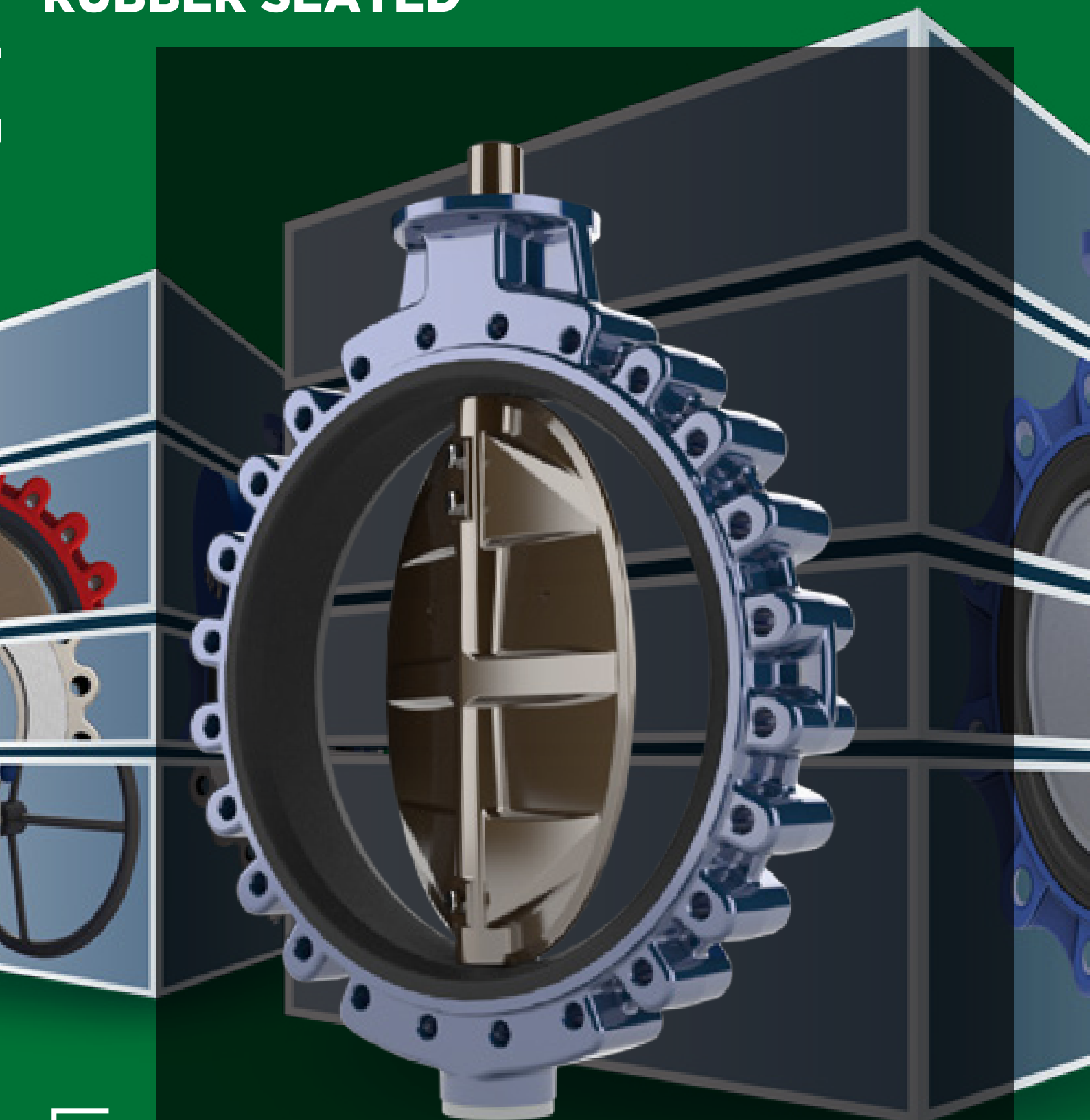

armakom DYSTRYBUTOR W POLSCE

**SOFT SEATED
RUBBER SEATED**



BVPD - Wafer BLPD - Lug
DN 50 - 500 • 2" - 20"

Soft seated butterfly valves
P max: 6 Bar designed for low pressures
and powder convey

BVKI - Wafer BLKI - Lug
DN 40 - 800 • 1" 1/4 - 32"

Soft seated butterfly valves
P max: 16 Bar designed for all applications

BFKI - double flange
DN 80 - 600 • 3" - 24"

Soft seated butterfly valves
P max: 16 Bar double flanged

BVKA - Wafer BLKA - Lug
DN 40 - 800 • 1" 1/4 - 32"

Soft seated butterfly valves
P max: 20 Bar

BVKX - Wafer BLKX - Lug
DN 50 - 250 • 2" - 10"

Soft seated butterfly valves
P max: 25 Bar

GHIBSON Soft seated butterfly valves are designed to meet with most industrial applications, from powder conveyance to petrochemical requirements.

The valves are manufactured in four different versions with sizes from DN 40 to DN 800, pressures up to 25 bar and many different materials.

We can supply valves

- manually operated (with levers or gearboxes)
- pneumatically operated (with double or single acting actuators)
- electrically or hydraulically operated

We also offer special solutions in many different materials.



Wide range of elastomers

A very wide range of elastomers allows the best combination of materials depending on the different applications

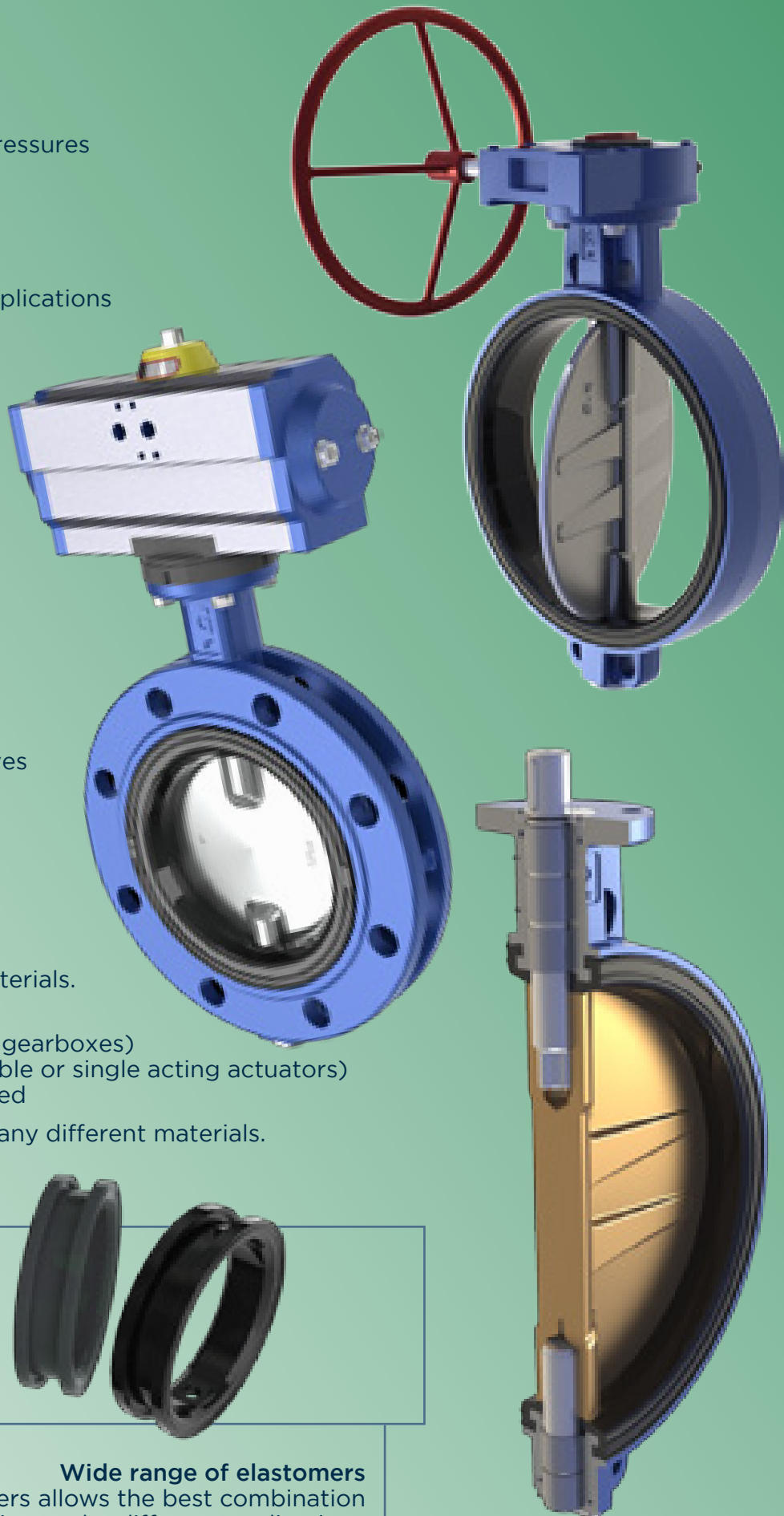



Detail of shaft-disc connection

Valves over DN300 have a special designed shaft-disc connection which ensures a strong coupling while avoiding clearances and gives higher shaft tensile capacity thanks to the section considerably larger than the classic square section.



Special shaft double packing

Sealing outwards is ensured by a double packing at the top and at the bottom of the shaft.

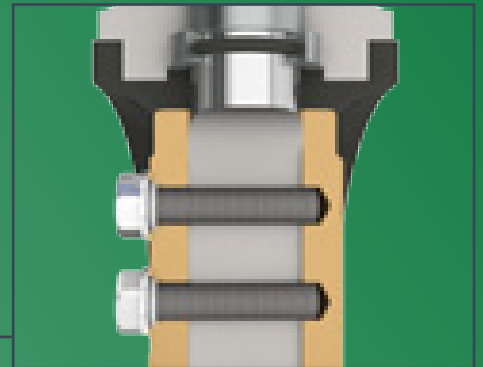

Detail of lower support

The adjustable lower support prevents the shaft-disc unit to move along the axis. Furthermore when the valve is assembled with vertical shaft, the disc does not weigh on the seat with a longer duration of valve life.

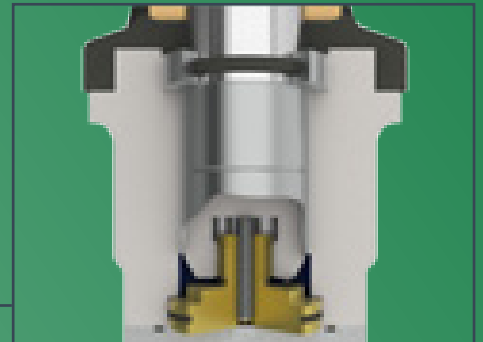

All **GIBSON** butterfly valves have anti-blow out system for the shafts in compliance with EN736 and API609 standards

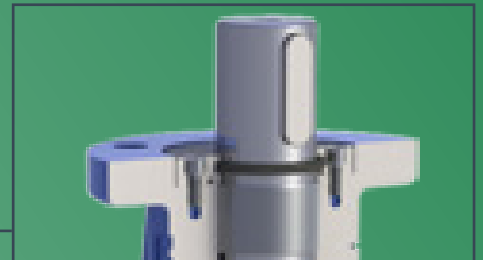

Detail of replaceable body seat

Its shape ensures the best anchoring to the body even in hard applications.

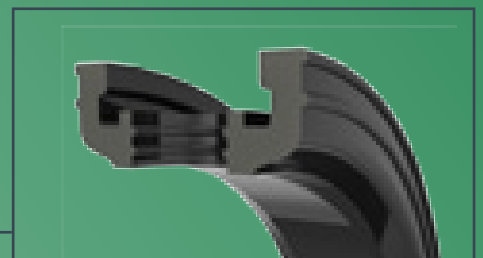

Detail of shaft-disc fastening

For valves over DN500 this solution allows a strong fastening without clearances and easy maintenance.



SOFT SEATED RUBBER SEATED

Ghibson soft seated butterfly valves (PD, KI, KA and KX series) are designed to fit in industrial applications from powder conveyance to marine and petrochemical requirements.

They are manufactured in different versions and materials and for working pressures from 6 to 25 Bars.

GHIBSON
Zola Predosa
Bologna

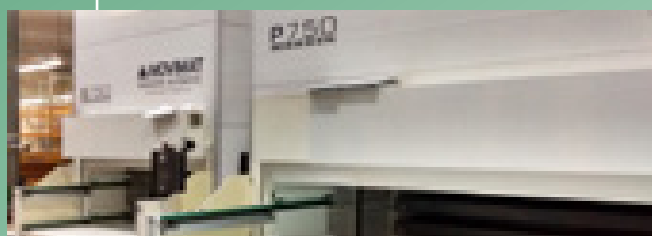

SOFT SEAT

PD, KI Series	1
• technical data	1
• components DN 80-300	2
• components DN 350-500	3
• components DN 600-800	4
KA, KX technical data	5
• technical data	5
KA series	6
• components DN 40-300	6
• components DN 350-400	7
• components DN 450-500	8
• components DN 600-800	9
KX series	10
• components DN 50-250	10
PD, KI, KA Series	11
• dimensions tables	11
BFKI, BVKX, BLKX Series	12
• dimensions tables	12
Torque values tables	13
Head losses tables	14
Flange and bolts tables	15
Flanges	16
Tests	16
Installation instructions	17
Handlever	18
Gearbox	19
• aluminium body	19
• cast iron body	20



BVPD-Wafer **BLPD**-Lug **BFPD**-double fl.
DN 80 - 600 • 3" - 24"

BVKI - Wafer **BLKI** - Lug
DN 40 - 800 • 1^{1/2} - 32"

BFKI - double flange
DN 80 - 600 • 3" - 24"

Max working pressure:

BVPD/BLPD/BFPD DN80÷600: **10 Bar**
Flange: **PN 6-10-16 • A150**

BVKI/BLKI DN40÷500: **16 Bar**
Flange: **PN 10-16 • A150**

BVKI/BLKI DN600÷800: **10 Bar**
Flange: **PN 6-10-16 • A150**

BFKI DN80÷600: **16 Bar**
Flange: **PN 10-16 • A150**

KI series to be used also with vacuum

Design:

EN 593 ~ EN 736 ~ EN 12516 ~ EN 1092
ISO 5211 ~ DIN 3337 ~ API 609
PED 97/23/EC(cat III) Mod H

Face to face:

DIN EN 558-1 Series 20 ~ ISO 5752 Series 20
BS-5155 Series 4 ~ MSS-SP67
API609 cat.A ~ NFE 29305-1

Testing:

EN 12266-1 Rate A ~ ISO 5208 Rate A
DIN 3230 ~ API 598

Tag:

EN 19 ~ MSS SP-25



TYPE APPROVAL



TYPE APPROVAL



GOST

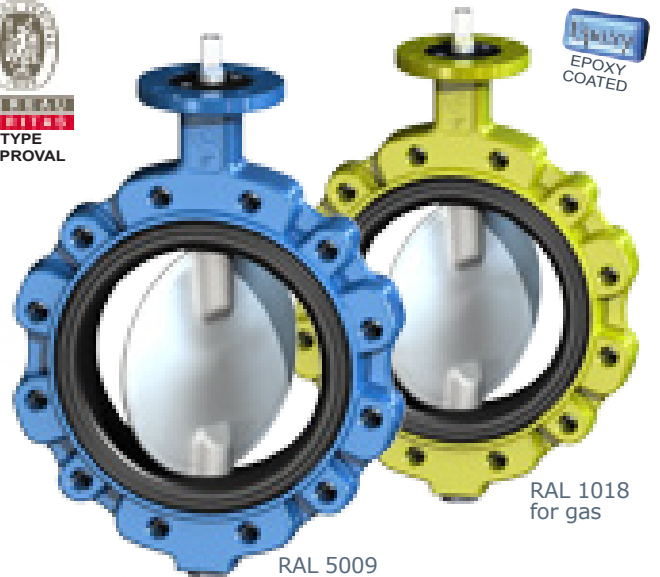

All valves are supplied with a metallic label in compliance with PED directive.

BODY			BVPD	BVKI/BLKI	BFKI/BFPD
material	references	standard coating	DN	DN	DN
Ductile iron	EN-GJS 400-15 (GS400)	Epoxy RAL 5009	80-600	40-800	80-600
Carbon steel	ASTM A216-WCB	Epoxy RAL 9005	80-600	40-800	-
Stainless steel	ASTM A351 CF8M (A316)	-	80-600	40-800	-
Aluminium-bronze	ASTM B148-C958.00	-	80-600	40-800	-
Aluminium (P _{max} 10Bar)	EN AB 46400	Epoxy RAL 7024	80-500	40-500 only wafer	-

DISC			BVPD	BVKI/BLKI	BFKI/BFPD
material	references	st.d coating	DN	DN	DN
Steel	ASTM A105	Zinc	50-100	50-100	80-100
Ductile iron	EN-GJS 400-15 (GS400)	Zinc	125-600	125-800	125-600
Stainless steel	ASTM A351 CF8M (A316)	-	80-600	40-800	80-600
Aluminium-bronze	ASTM B148-C958.00	-	80-600	40-800	80-600
Hastelloy®	ASTM A494 CX2MW	-	80-600	40-800	80-600
Monel®	ASTM A494 M35-1	-	80-600	40-800	80-600

BODY RUBBER SEAT					
DN 40/500 replaceable - DN 600/800 vulcanized not replaceable					
ref.	designation	PD P _{max}	trade name	working temp.	applications
NBR	nitrile rubber	10Bar	BUNA®	-25°C / +100°C	oils, hydrocarbons, gas, air, water
EPDM	copolymer EPDM	10Bar	-	-35°C / +130°C	water, sea water, steam, diluted acids
EPDM HT	copolimery EPDM HT	10Bar	-	-30°C / +135°C	water, sea water, steam, diluted acids
CO	carboxide	6Bar	-	-25°C / +100°C	dust, air
FKM	fluoroelastomer	6Bar	VITON®	-20°C / +200°C	oils, acids, hydrocabons
CR	polychloroprene	6Bar	NEOPRENE®	-20°C / +100°C	alkali, bases, water
NR	natural rubber	6Bar	-	-40°C / + 80°C	glycols, abrasive media
MVQ	silicon rubber	6Bar	SILOPREN®	-60°C / +190°C	water, food, drinks
CSM	chlorosulfonated polyethylene	6Bar	HYPALON®	-20°C / +125°C	acids, mineral bases, alcohols, hydrocarbons

On request can be supplied other materials as: LCB, Hastelloy, Monel, Uranus, Alloy, DUPLEX, Special steels, Special bronzes.
Coating on request: RILSAN®, Halar®, Chenisil®

BVPD-Wafer **BLPD**-Lug **BFPD**- double fl.
 DN 80 - 300 • 3" - 12"
 PN 6-10-16 • ANSI 150

BVKI - Wafer **BLKI** - Lug
 DN 40 - 300 • 1 1/2" - 12"
 PN 10-16 • ANSI 150

BFKI - double flange
 DN 80 - 300 • 3" - 12"
 PN 10-16 • ANSI 150

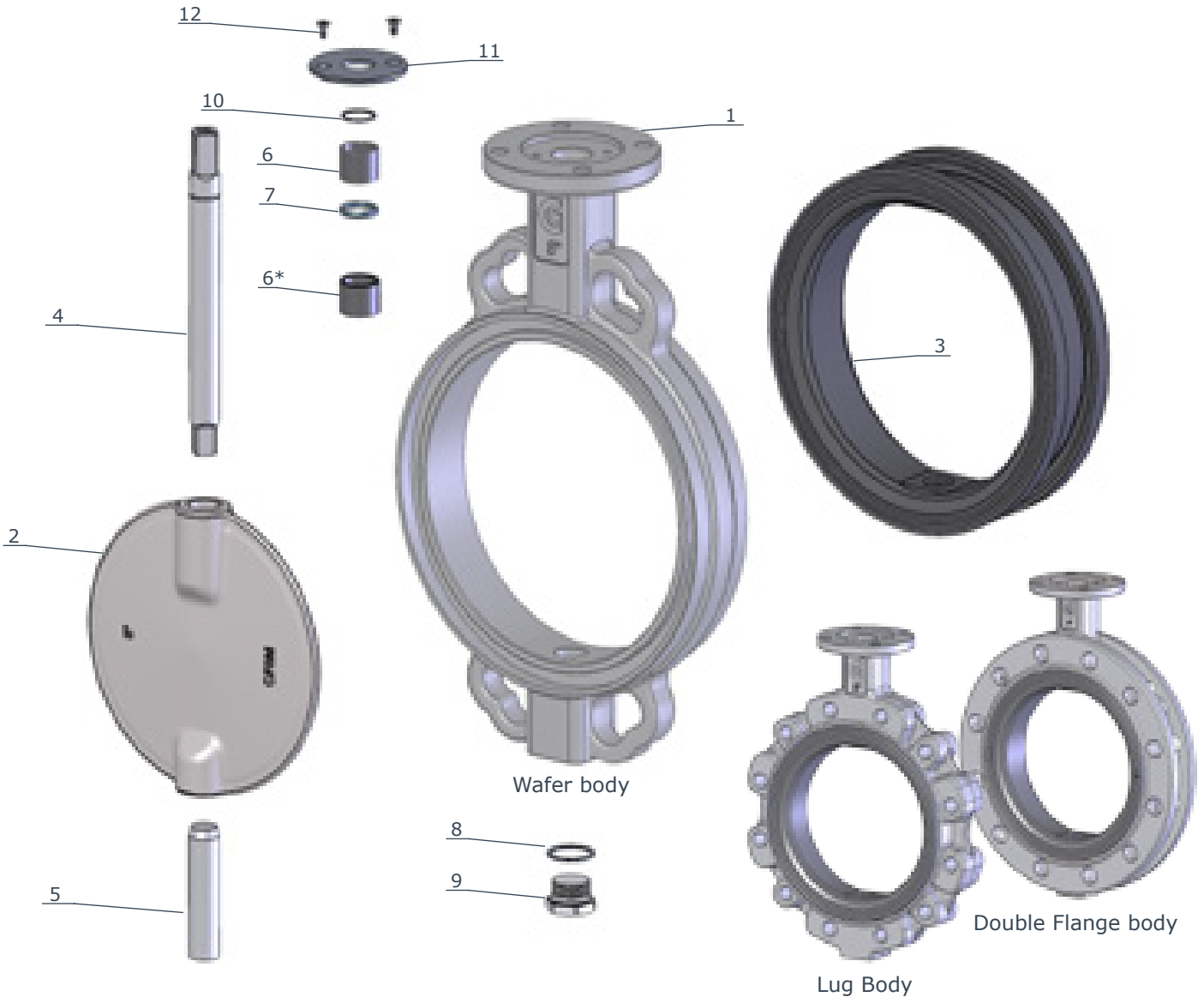

item	q.ty	part	material	item	q.ty	part	material
1	1	body (BFKI only GS400)	<ul style="list-style-type: none"> ductile iron GS400 A216 - WCB A352 - LCB A351 - CF8M (AISI 316) aluminium-bronze aluminium (only WAFER) 	4	1	upper shaft	<ul style="list-style-type: none"> AISI 430 AISI 316 (on request)
2	1	disc	<ul style="list-style-type: none"> ductile iron GS400 A351 - CF8M (AISI 316) aluminium-bronze Hastelloy® Monel® 	5	1	lower shaft	<ul style="list-style-type: none"> AISI 430 AISI 316 (on request)
◇3	1	body seat (replaceable)	<ul style="list-style-type: none"> NBR (BUNA®) EPDM EPDM HT FKM (VITON®) carboxide polychloroprene (NEOPRENE®) natural rubber silicon 	◇6	1	bush	bronze
				◇6*	1	bush	bronze
				◇7	1	shaft packing	<ul style="list-style-type: none"> NBR (BUNA®) FKM (VITON®) on request
				8	1	plug packing	aluminium
				9	1	threaded plug	zinc plated steel
				10	1	stop ring	steel
				11	1	upper flange	<ul style="list-style-type: none"> IXEF (DN 40-150) aluminium (DN 200-300)
				12	2	screw	zinc plated steel

◇ parts included in spare kit

* only for DN300

BVPD-Wafer **BLPD**-Lug **BFPD**- double fl. **BVKI** - Wafer **BLKI** - Lug **BFKI** - double flange
 DN 350 - 500 • 14" - 20" | DN 350 - 500 • 14" - 20" | DN 350 - 500 • 14" - 20"
 PN 6-10-16 • ANSI 150 | PN 10-16 • ANSI 150 | PN 10-16 • ANSI 150

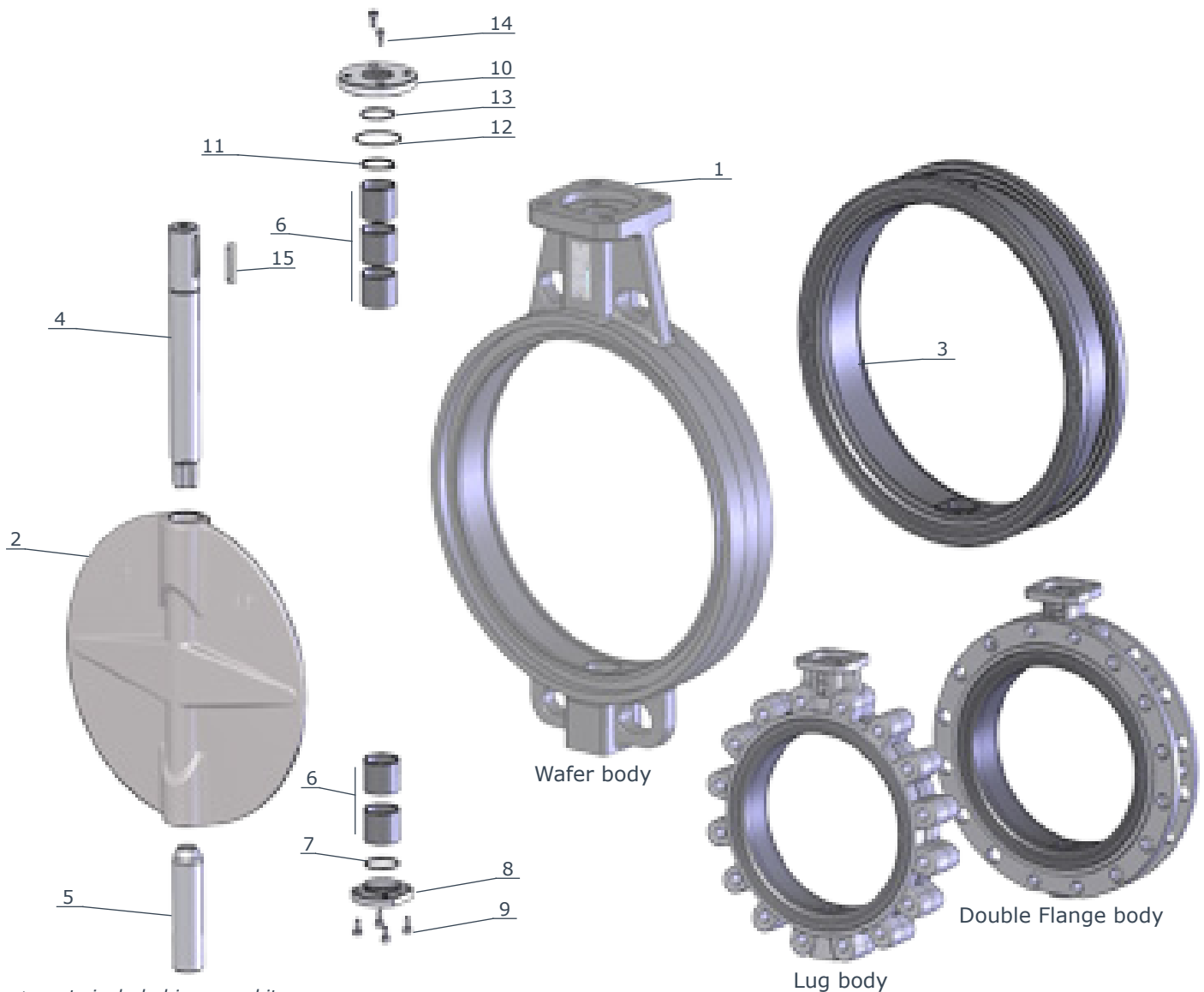

◇ parts included in spare kit

item	q.ty	part	material	item	q.ty	part	material
1	1	body (BFKI only GS400)	<ul style="list-style-type: none"> ductile iron GS400 A216-WCB A352-LCB A351-CF8M (AISI 316) aluminium-bronze aluminium (only WAFER) 	5	1	lower shaft	<ul style="list-style-type: none"> AISI 430 AISI 316 (on request)
2	1	disc	<ul style="list-style-type: none"> ductile iron GS400 A351-CF8M (AISI 316) aluminium-bronze Hastelloy® Monel® 	◇6	5	bush	<ul style="list-style-type: none"> bronze steel+PTFE (DN 450-500)
◇3	1	body seat (replaceable)	<ul style="list-style-type: none"> NBR (BUNA®) EPDM EPDM HT FKM (VITON®) carboxide polychloroprene (NEOPRENE®) natural rubber silicon 	◇7	1	packing lower flange	<ul style="list-style-type: none"> NBR (BUNA®)
4	1	upper shaft	<ul style="list-style-type: none"> AISI 430 AISI 316 (on request) 	8	1	lower flange	<ul style="list-style-type: none"> zinc plated steel
				9	4	screw	<ul style="list-style-type: none"> zinc plated steel
				10	1	upper flange	<ul style="list-style-type: none"> zinc plated steel
				11	1	stop ring	<ul style="list-style-type: none"> steel
				◇12	1	O.Ring	<ul style="list-style-type: none"> NBR (BUNA®)
				◇13	1	O.Ring	<ul style="list-style-type: none"> NBR (BUNA®)
				14	2	screw	<ul style="list-style-type: none"> zinc plated steel
				15	1	key	<ul style="list-style-type: none"> steel C40

BVPD-Wafer **BLPD**-Lug **BFPD**-double fl.
 DN 600 • 24"
 PN 6-10-16 • ANSI 150

BVKI - Wafer **BLKI** - Lug
 DN 600 - 800 • 24" - 32"
 PN 6-10-16 • ANSI 150

BFKI - double flange
 DN 600 • 24"
 PN 10-16 • ANSI 150

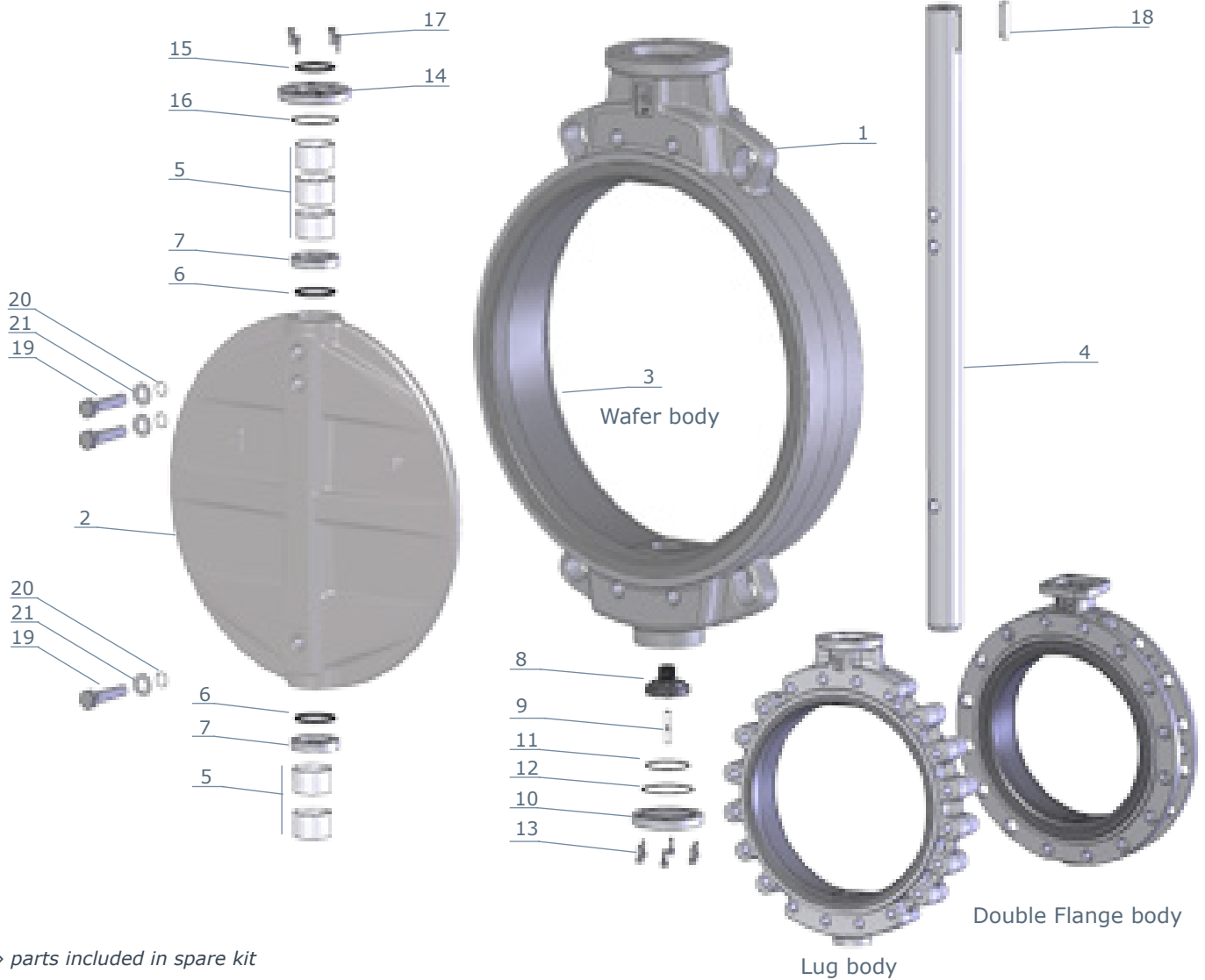

◇ parts included in spare kit

item	q.ty	part	material	item	q.ty	part	material
1	1	body (BFKI only GS400)	<ul style="list-style-type: none"> ductile iron GS400 A216-WCB A352-LCB A351-CF8M (AISI 316) aluminium-bronze 	7	2	O.ring housing	• AISI 316
2	1	disc	<ul style="list-style-type: none"> ductile iron GS400 A351 - CF8M (AISI 316) aluminium-bronze Hastelloy® Monel® 	8	1	shaft support	• Bronze
3	1	body seat (vulcanized not replaceable)	<ul style="list-style-type: none"> NBR (BUNA®) EPDM EPDM HT FKM (VITON®) 	9	2	adjusting screw	• AISI 316
4	1	shaft	<ul style="list-style-type: none"> AISI 303 AISI 316 (on request) 	10	1	lower flange	• zinc plated steel
◇5	5	bush	• steel + PTFE	◇11	1	O.ring	• NBR (BUNA®)
◇6	2	shaft O.ring	<ul style="list-style-type: none"> NBR (BUNA®) FKM (VITON®) on request 	◇12	1	O.ring	• NBR (BUNA®)
				13	6	screw	• zinc plated steel
				14	1	upper flange	• zinc plated steel
				◇15	1	O.ring	• NBR (BUNA®)
				◇16	1	O.ring	• NBR (BUNA®)
				17	4	screw	• zinc plated steel
				18	1	key	• steel
				19	3	screw	• AISI 316
				◇20	3	O.ring	• PTFE
				21	3	washer	• AISI 316

BVKA - Wafer **BLKA** - Lug
DN 40 - 800 • 1"1/2 - 32"

BVKX - Wafer
DN 50 - 250 • 2" - 10"

BLKX - Lug
DN 50 - 200 • 2" - 8"

Max working pressure:

BVKA/BLKA DN 40÷800: **20 Bar**
Flange: **PN 10-16 • A150**

BVKX DN 50÷250: **25 Bar**

BLKX DN 50÷200: **25 Bar**
Flange: **PN 16-25 • A150**

To be used also with vacuum

Design:

EN 593 ~ EN 736 ~ EN 12516 ~ EN 1092
ISO 5211 ~ DIN 3337 ~ API 609
PED 97/23/EC(cat III) Mod H

Face to face:

DIN EN 558-1 Series 20 ~ ISO 5752 Series 20
BS-5155 Series 4 ~ MSS-SP67
API609 cat.A ~ NFE 29305-1

Testing:

EN 12266-1 Rate A ~ ISO 5208 Rate A
DIN 3230 ~ API 598

Tag:

EN 19 ~ MSS SP-25



All valves are supplied with a metallic label in compliance with PED directive.

BODY			BVKA/BLKA	BVKX	BLKX
material	references	standard coating	DN	DN	DN
Ductile iron	EN-GJS 400-15 (GS400)	Epoxy RAL 5009	40-800	50-250	50-200
Carbon steel	ASTM A216-WCB	Epoxy RAL 9005	40-800	50-100	50-100
Stainless steel	ASTM A351 CF8M (A316)	-	40-800	50-100	50-100
Aluminium-bronze	ASTM B148-C958.00	-	40-800	50-100	50-100

DISC			BVKA/BLKA	BVKX	BLKX
material	references	standard coating	DN	DN	DN
Stainless steel	ASTM A351 CF8M (A316)	-	40-800	50-250	50-200
Aluminium-bronze	ASTM B148-C958.00	-	40-800	50-250	50-200
Hastelloy®	ASTM A494 CX2MW	-	40-800	50-250	50-200
Monel®	ASTM A494 M35-1	-	40-800	50-250	50-200

BODY RUBBER SEAT		KA DN 40/150 replaceable - DN 200/800 vulcanized not replaceable KX DN 50/250 vulcanized not replaceable		
ref.	designation	trade name	working temp.	applications
NBR	nitrile rubber	BUNA®	-25°C / +100°C	oils, hydrocarbons, gas, air, water
EPDM	copolymer EPDM	-	-35°C / +130°C	water, sea water, steam, diluted acids
EPDM HT	copolimery EPDM HT	-	-30°C / +135°C	water, sea water, steam, diluted acids
FKM	fluoroelastomer	VITON®	-20°C / +200°C	oils, acids, hydrocabons

On request can be supplied other materials as: LCB, Hastelloy, Monel, Uranus, Alloy, DUPLEX, Special steels, Special bronzes.
Coating on request: RILSAN®, Halar®, Chenisil®

BVKA - Wafer BLKA - Lug
 DN 40 - 150 • 1 1/2" - 6"
 PN 10-16 • ANSI 150



item	q.ty	part	material
1	1	body	<ul style="list-style-type: none"> ductile iron GS400 A216 - WCB A352 - LCB A351 - CF8M (AISI 316) aluminium-bronze Hastelloy® Monel®
2	1	disc	<ul style="list-style-type: none"> A351 - CF8M (AISI 316) aluminium-bronze Hastelloy® Monel®
◇3	1	body seat (replaceable)	<ul style="list-style-type: none"> NBR (BUNA®) EPDM EPDM HT FKM (VITON®)
4	1	upper shaft	<ul style="list-style-type: none"> AISI 430 AISI 316 (on request)
5	1	lower shaft	<ul style="list-style-type: none"> AISI 430 AISI 316 (on request)
◇6	1	bush	<ul style="list-style-type: none"> bronze
◇7	1	shaft packing	<ul style="list-style-type: none"> NBR (BUNA®) FKM (VITON®) (on request)
8	1	plug packing	<ul style="list-style-type: none"> aluminium
9	1	threaded plug	<ul style="list-style-type: none"> zinc plated steel
10	1	stop ring	<ul style="list-style-type: none"> steel
11	1	upper flange	<ul style="list-style-type: none"> IXEF (DN 40-150)
12	2	screw	<ul style="list-style-type: none"> zinc plated steel

◇ parts included in spare kit

BVKA - Wafer BLKA - Lug
 DN 200 - 300 • 8" - 12"
 PN 10-16 • ANSI 150

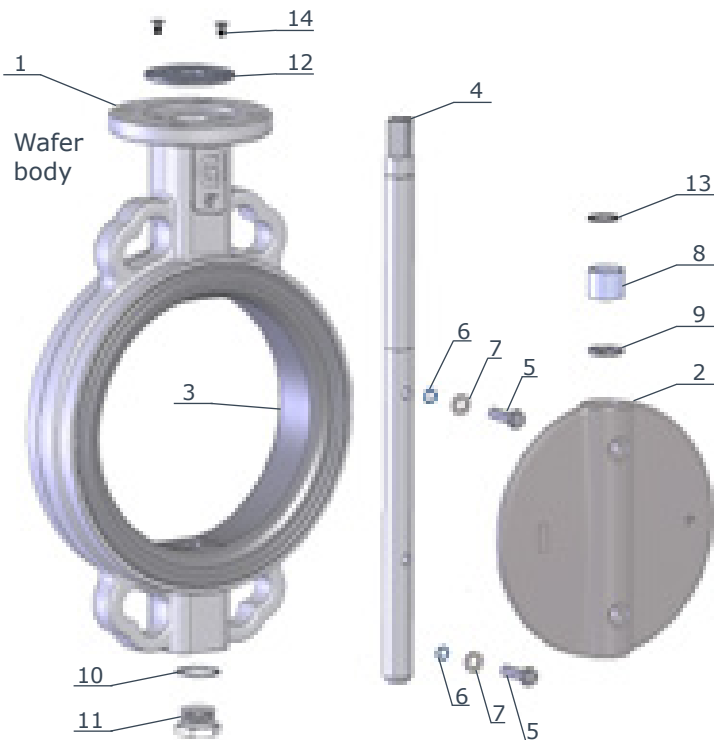

item	q.ty	part	material
1	1	body	<ul style="list-style-type: none"> ductile iron GS400 A216-WCB A352-LCB A351-CF8M (AISI 316) aluminium-bronze
2	1	disc	<ul style="list-style-type: none"> A351-CF8M (AISI 316) aluminium-bronze Hastelloy® Monel®
3	1	body seat (vulcanized not replaceable)	<ul style="list-style-type: none"> NBR (BUNA®) EPDM EPDM HT FKM (VITON®)
4	1	shaft	<ul style="list-style-type: none"> AISI 430 AISI 316 (on request)
5	2	screw	<ul style="list-style-type: none"> AISI 316
◇6	2	O.Ring	<ul style="list-style-type: none"> PTFE
7	2	washer	<ul style="list-style-type: none"> AISI 316
◇8	1	bush	<ul style="list-style-type: none"> bronze
◇9	1	shaft packing	<ul style="list-style-type: none"> NBR (BUNA®) FKM (VITON®) (on req.)
10	1	plug packing	<ul style="list-style-type: none"> aluminium
11	1	threaded plug	<ul style="list-style-type: none"> zinc plated steel
12	1	upper flange	<ul style="list-style-type: none"> aluminium
13	1	stop ring	<ul style="list-style-type: none"> steel
14	2	screw	<ul style="list-style-type: none"> zinc plated steel

◇ parts included in spare kit

BVKA - Wafer **BLKA** - Lug
 DN 350 - 400 • 14" - 16"
 PN 10-16 • ANSI 150

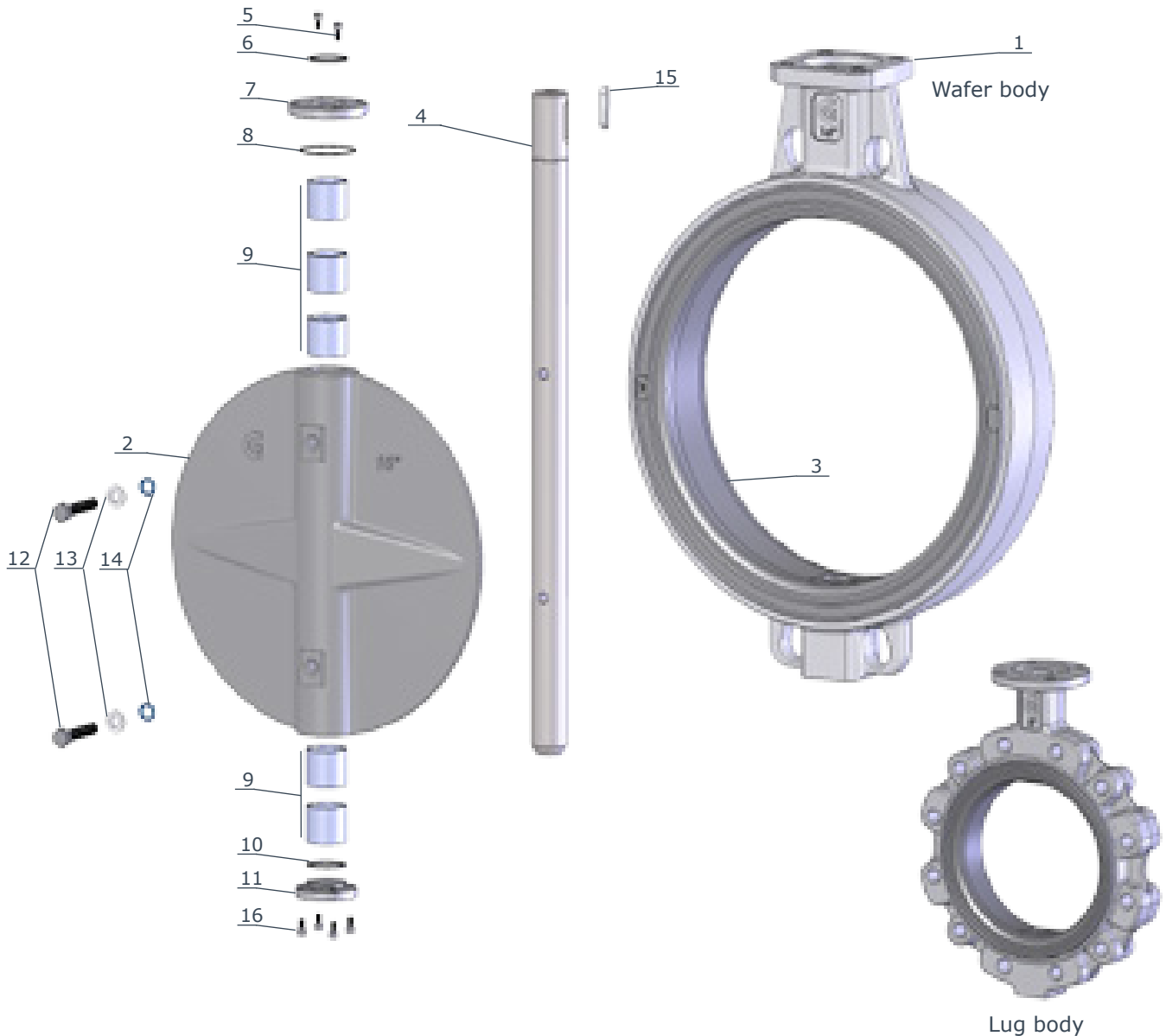

◇ parts included in spare kit

item	q.ty	part	material	item	q.ty	part	material
1	1	body	<ul style="list-style-type: none"> ductile iron GS400 A216-WCB A352-LCB A351-CF8M (AISI 316) aluminium-bronze 	5	2	screw	<ul style="list-style-type: none"> zinc plated steel
2	1	disc	<ul style="list-style-type: none"> A351 - CF8M (AISI 316) aluminium-bronze Hastelloy® Monel® 	◇6	1	O.ring	<ul style="list-style-type: none"> NBR (BUNA®)
3	1	body seat (vulcanized not replaceable)	<ul style="list-style-type: none"> NBR (BUNA®) EPDM EPDM HT FKM (VITON®) 	7	1	upper flange	<ul style="list-style-type: none"> zinc plated steel
4	1	shaft	<ul style="list-style-type: none"> AISI 430 AISI 316 (on request) 	◇8	1	O.ring	<ul style="list-style-type: none"> NBR (BUNA®)
				◇9	5	bush	<ul style="list-style-type: none"> bronze
				◇10	1	O.ring	<ul style="list-style-type: none"> NBR (BUNA®)
				11	1	lower flange	<ul style="list-style-type: none"> zinc plated steel
				12	2	screw	<ul style="list-style-type: none"> AISI 316
				13	2	washer	<ul style="list-style-type: none"> AISI 316
				◇14	2	O. ring	<ul style="list-style-type: none"> PTFE
				15	1	key	<ul style="list-style-type: none"> steel C40
				16	4	screw	<ul style="list-style-type: none"> zinc plated steel

BVKA - Wafer **BLKA** - Lug
 DN 450 - 500 • 18" - 20"
 PN 10-16 • ANSI 150

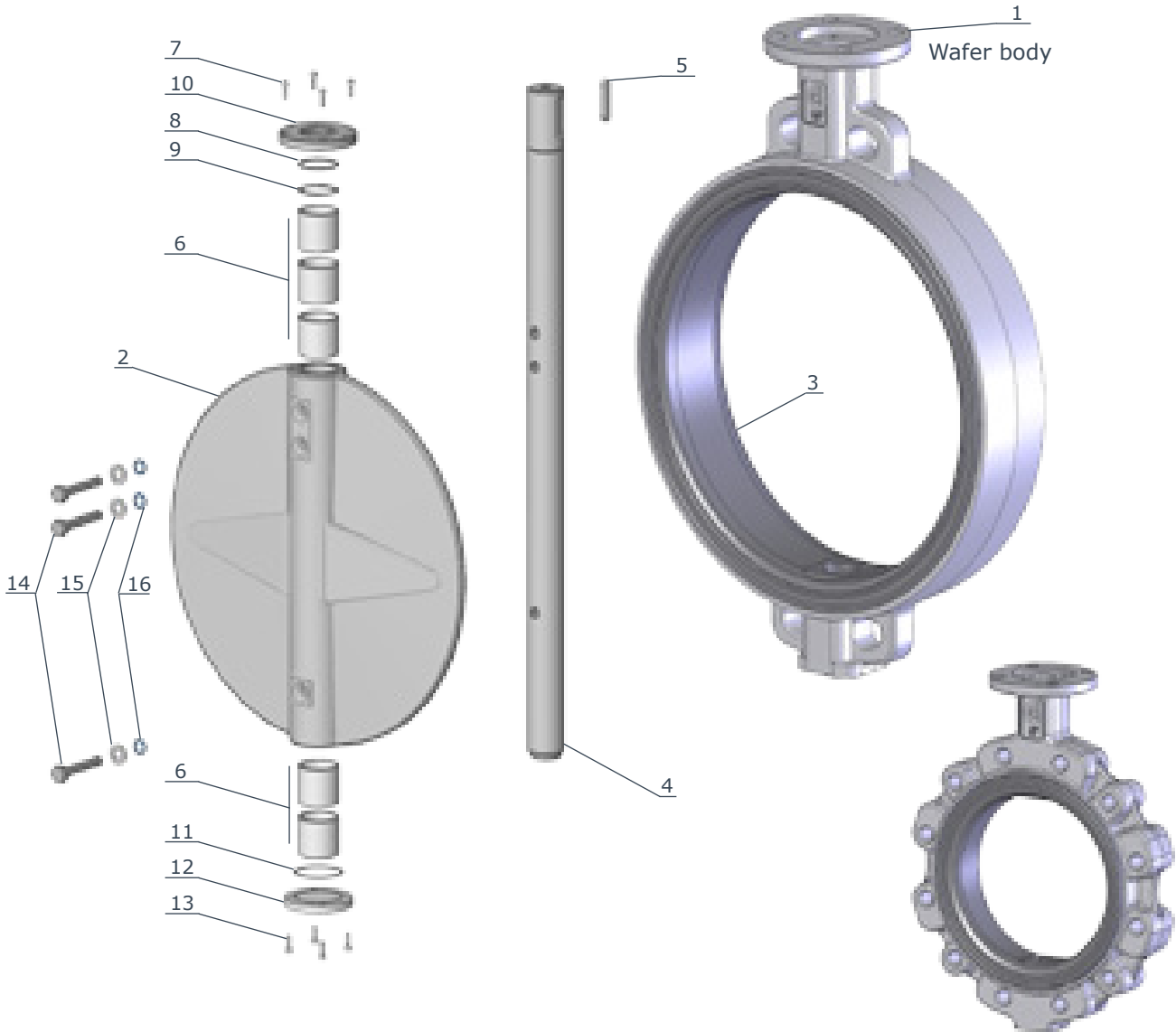

◇ parts included in spare kit

item	q.ty	part	material	item	q.ty	part	material
1	1	body	<ul style="list-style-type: none"> ductile iron GS400 A216-WCB A352-LCB A351-CF8M (AISI 316) aluminium-bronze 	◇6	5	bush	• steel + PTFE
2	1	disc	<ul style="list-style-type: none"> A351 - CF8M (AISI 316) aluminium-bronze Hastelloy® Monel® 	7	4	screw	• zinc plated steel
3	1	body seat (vulcanized not replaceable)	<ul style="list-style-type: none"> NBR (BUNA®) EPDM EPDM HT FKM (VITON®) 	◇8	1	O.ring	• NBR (BUNA®)
4	1	shaft	<ul style="list-style-type: none"> AISI 430 AISI 316 (on request) 	9	5	stop ring	• steel
5	1	key	• steel C40	10	1	upper flange	• zinc plated steel
				◇11	1	O.ring	• NBR (BUNA®)
				12	1	lower flange	• zinc plated steel
				13	4	screw	• steel
				14	2	screw	• AISI 316
				15	2	washer	• AISI 316
				◇16	2	O. ring	• PTFE

BVKA - Wafer BLKA - Lug
 DN 600 - 800 • 24" - 32"
 PN 16 • ANSI 150

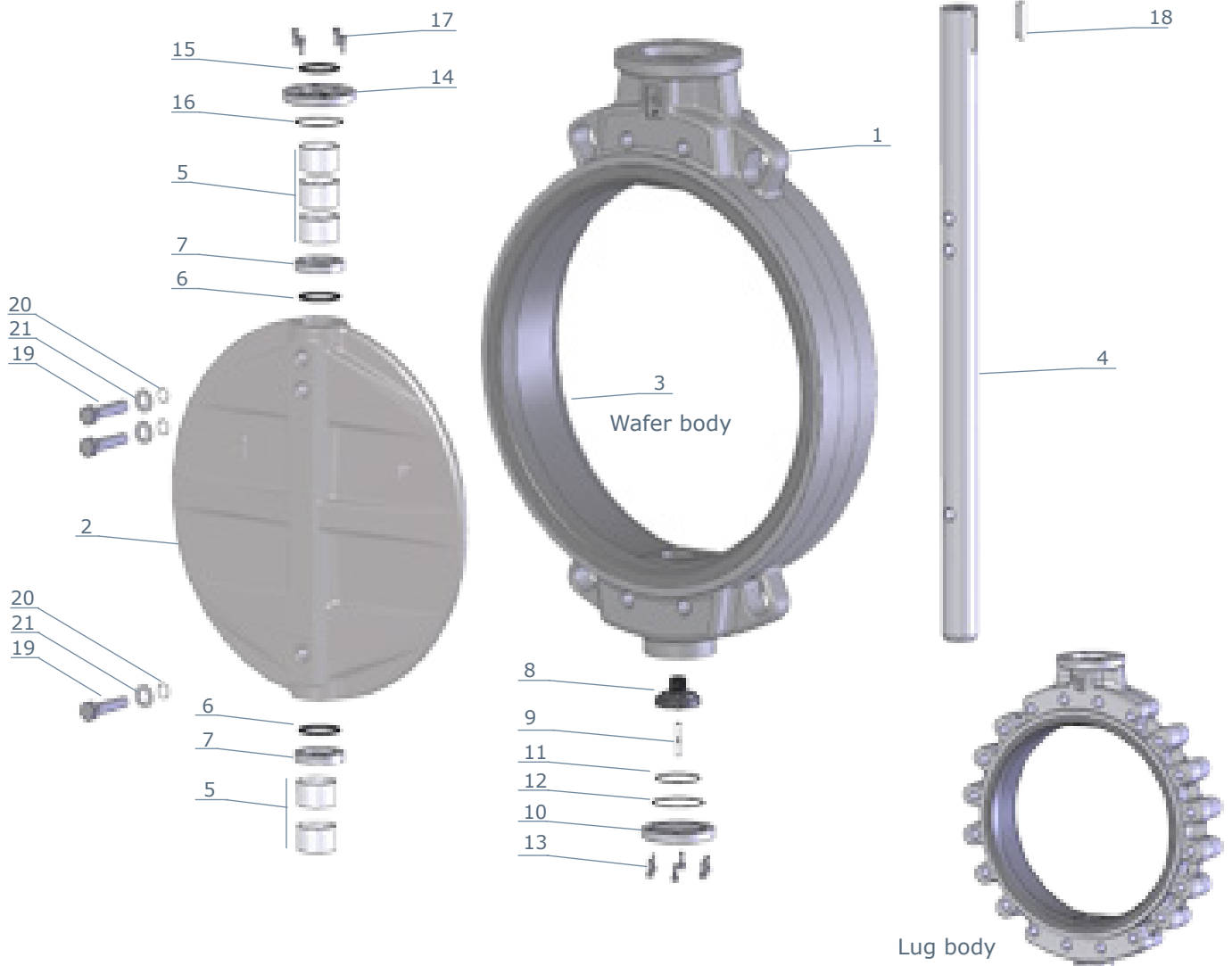

◇ parts included in spare kit

item	q.ty	part	material	item	q.ty	part	material
1	1	body	<ul style="list-style-type: none"> ductile iron GS400 A216-WCB A352-LCB A351-CF8M (AISI 316) aluminium-bronze 	7	2	O.ring housing	<ul style="list-style-type: none"> AISI 316
2	1	disc	<ul style="list-style-type: none"> ductile iron GS400 A351 - CF8M (AISI 316) aluminium-bronze Hastelloy® Monel® 	8	1	shaft support	<ul style="list-style-type: none"> Bronze
3	1	body seat (vulcanized not replaceable)	<ul style="list-style-type: none"> NBR (BUNA®) EPDM EPDM HT FKM (VITON®) 	9	2	adjusting screw	<ul style="list-style-type: none"> AISI 316
4	1	shaft	<ul style="list-style-type: none"> AISI 303 AISI 316 (on request) 	10	1	lower flange	<ul style="list-style-type: none"> zinc plated steel
◇5	5	bush	<ul style="list-style-type: none"> steel + PTFE 	◇11	1	O.ring	<ul style="list-style-type: none"> NBR (BUNA®)
◇6	2	O.ring	<ul style="list-style-type: none"> NBR (BUNA®) FKM (VITON®) on request 	◇12	1	O.ring	<ul style="list-style-type: none"> NBR (BUNA®)
				13	6	screw	<ul style="list-style-type: none"> zinc plated steel
				14	1	upper flange	<ul style="list-style-type: none"> zinc plated steel
				◇15	1	O.ring	<ul style="list-style-type: none"> NBR (BUNA®)
				◇16	1	O.ring	<ul style="list-style-type: none"> NBR (BUNA®)
				17	4	screw	<ul style="list-style-type: none"> zinc plated steel
				18	1	key	<ul style="list-style-type: none"> steel
				19	3	screw	<ul style="list-style-type: none"> AISI 316
				◇20	3	O.ring	<ul style="list-style-type: none"> PTFE
				21	3	washer	<ul style="list-style-type: none"> AISI 316

BVKX - Wafer BLKX - Lug

DN 50 - 100 • 2" - 4"
PN 16-25 • ANSI 150

item	q.ty	part	material
1	1	body	<ul style="list-style-type: none"> ductile iron GS400 A216 - WCB A352 - LCB A351 - CF8M (AISI 316)
2	1	disc	<ul style="list-style-type: none"> A351 - CF8M (AISI 316) aluminium-bronze Hastelloy® Monel®
3	1	body seat (vulcanized not replaceable)	<ul style="list-style-type: none"> NBR (BUNA®) EPDM EPDM HT FKM (VITON®)
4	1	upper shaft	<ul style="list-style-type: none"> AISI 430 AISI 316 (on request)
5	1	lower shaft	<ul style="list-style-type: none"> AISI 430 AISI 316 (on request)
◇6	1	bush	bronze
◇7	1	shaft packing	<ul style="list-style-type: none"> NBR (BUNA®) FKM (VITON®) on req.
8	1	plug packing	aluminium
9	1	threaded plug	zinc plated steel
10	1	stop ring	steel
11	1	upper flange	IXEF (DN 50-100)
12	2	screw	zinc plated steel
◇13	2	upper bush	steel + PTFE
◇14	2	lower bush	steel + PTFE

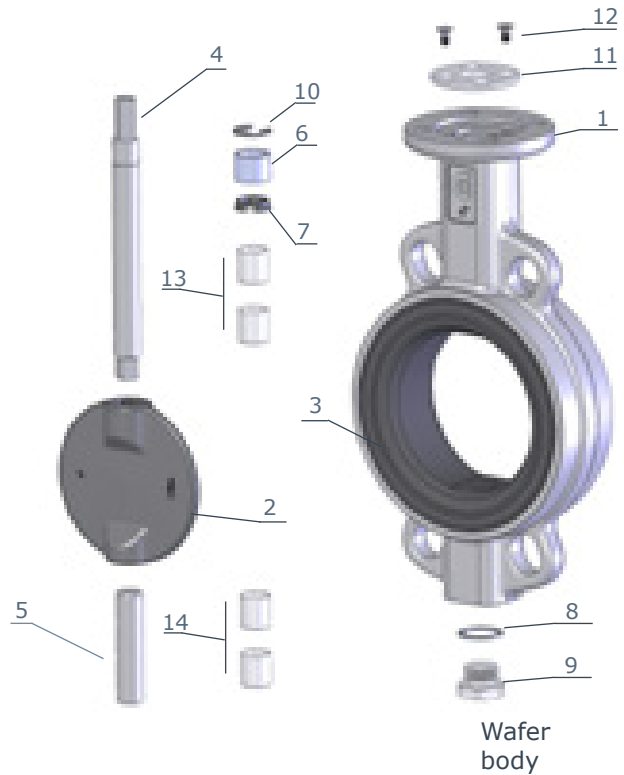

◇ parts included in spare kit

BVKX - Wafer

DN 125 - 250 • 5" - 10"
PN 16-25 • ANSI 150

BLKX - Lug

DN 125 - 200 • 5" - 8"
PN 16-25 • ANSI 150

item	q.ty	part	material
1	1	body	ductile iron GS400
2	1	disc	<ul style="list-style-type: none"> A351-CF8M (AISI 316) aluminium-bronze Hastelloy® Monel®
3	1	body seat (vulcanized not replaceable)	<ul style="list-style-type: none"> NBR (BUNA®) EPDM EPDM HT FKM (VITON®)
4	1	shaft	<ul style="list-style-type: none"> AISI 430 AISI 316 (on request)
5	2	screw	AISI 316
◇6	2	O.Ring	PTFE
7	2	washer	AISI 316
◇8	1	bush	bronze
◇9	1	shaft packing	<ul style="list-style-type: none"> NBR (BUNA®) FKM (VITON®) (on req.)
10	1	plug packing	aluminium
11	1	threaded plug	zinc plated steel
12	1	upper flange	<ul style="list-style-type: none"> IXEF (DN 125-150) aluminium (DN 200-250)
13	1	stop ring	steel
14	2	screw	zinc plated steel
◇15	2	upper bush	steel + PTFE
◇16	2	lower bush	steel + PTFE

◇ parts included in spare kit

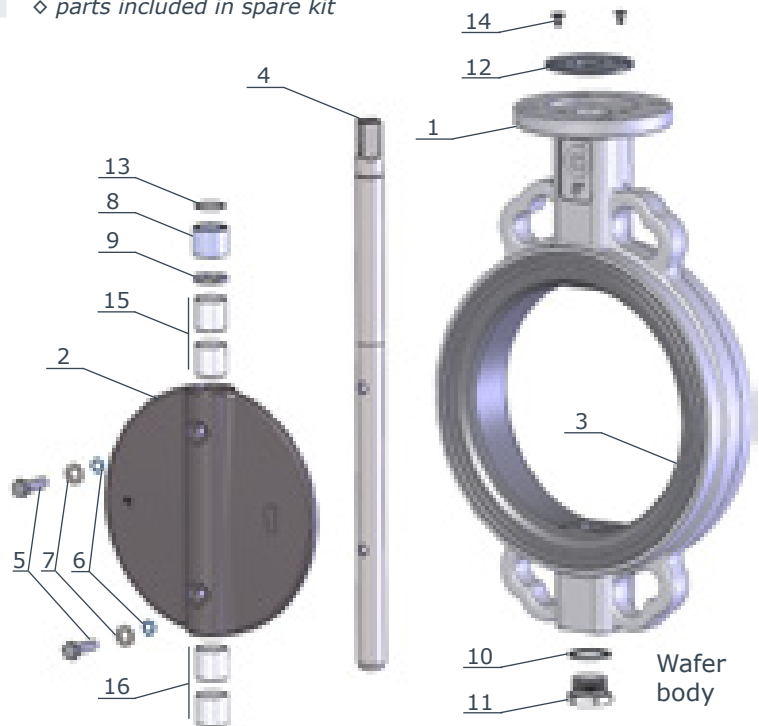

BVPD - Wafer | **BLPD - Lug** | **BVKI - Wafer** | **BLKI - Lug** | **BVKA - Wafer** | **BLKA - Lug**

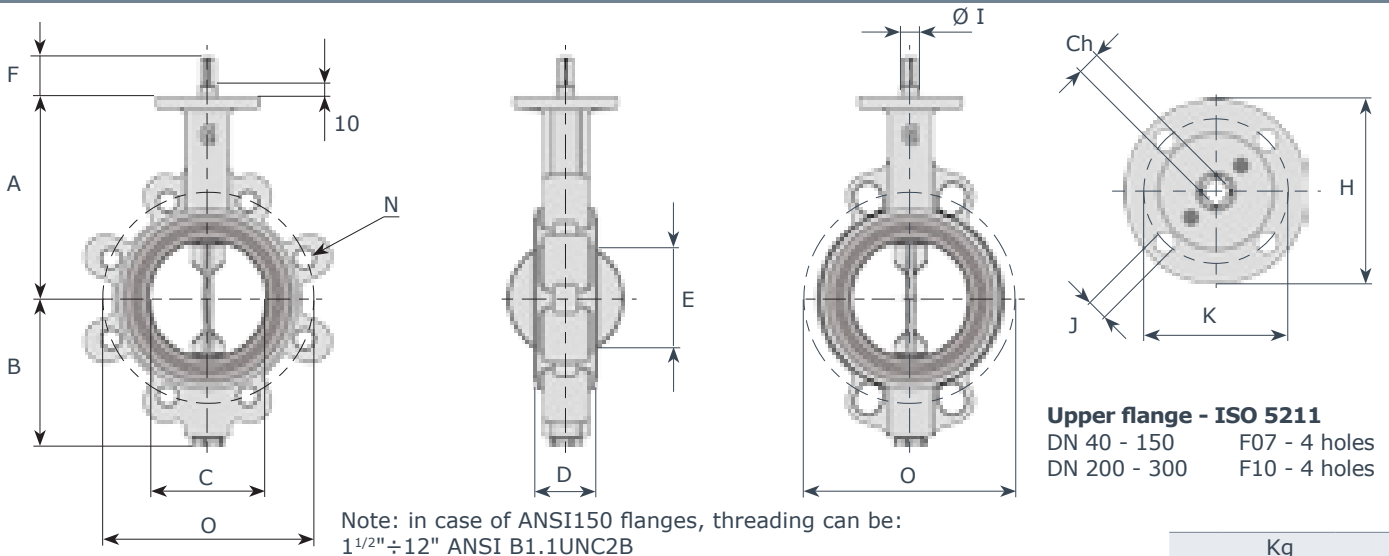

DN	A	B	C	D	E	F	Ø I	Ch	H	K	J	Kg															
												PN 6			PN 10			PN 16			ANSI 150			PD-KI		KA	
												N	n.	O	N	n.	O	N	n.	O	N	n.	O	W	L	W	L
40	130	75	49	33	36	34	14	11	90	70	9	-	-	-	M16	4	110	M16	4	110	M14	4	98.4	2.2	3	2.2	3
50	138	81	55	43	35	34	14	11	90	70	9	M12	4	110	M16	4	125	M16	4	125	M16	4	120.6	2.8	3.7	2.8	3.7
65	144	98	68	46	50	34	14	11	90	70	9	M12	4	130	M16	8	145	M16	8	145	M16	4	139.7	3.7	5.3	3.7	5.3
80	158	110	81	46	67	34	14	11	90	70	9	M16	4	150	M16	8	160	M16	8	160	M16	4	152.4	4	6.1	4	6.1
100	173	128	101	52	87	34	16	11	90	70	9	M16	4	170	M16	8	180	M16	8	180	M16	8	190.5	6	8.1	6	8.1
125	186	140	126	56	113	34	18	14	90	70	9	M16	8	200	M16	8	210	M16	8	210	M20	8	215.9	7.2	9.7	7.2	9.7
150	202	155	150	56	140	34	18	14	90	70	9	M16	8	225	M20	8	240	M20	8	240	M20	8	241.3	9.1	11.5	9.5	11.8
200	240	190	200	60	191	38	22	17	125	102	11	M16	8	280	M20	8	295	M20	12	295	M20	8	298.4	14	27	16	29
250	270	220	250	68	241	38	30	22	125	102	11	M16	12	335	M20	12	350	M24	12	355	M22	12	361.9	22	34	26	38
300	300	247	298	78	289	38	30	22	125	102	11	M20	12	395	M20	12	400	M24	12	410	M22	12	431.8	32	49	36	53

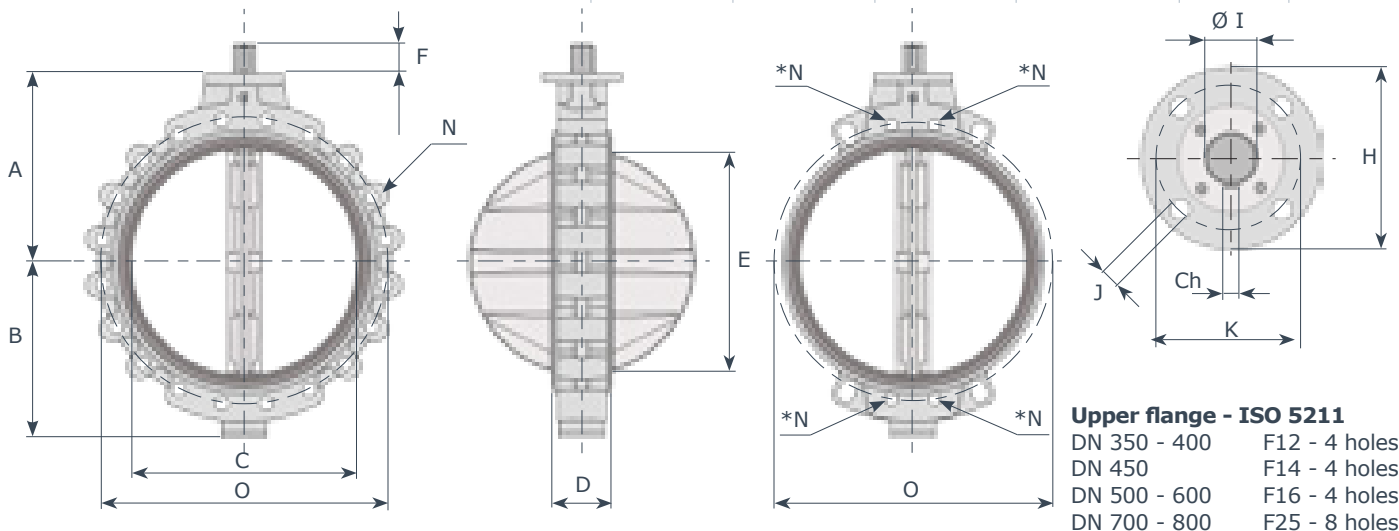

Note: in case of ANSI150 flanges, threading can be:
 14" ANSI B1.1UNC2B
 16" ÷ 32" ANSI B1.1-8 UNC2B

*Note: WAFER bodies DN 600 - 700 - 800 have 4 holes N threaded as relevant LUG version

DN	A	B	C	D	E	F	Ø I	Ch	H	K	J	Kg															
												PN 6			PN 10			PN 16			ANSI 150			PD-KI		KA	
												N	n.	O	N	n.	O	N	n.	O	N	n.	O	W	L	W	L
350	330	280	341	78	332	60	35	10	150	125	14	M20	12	445	M20	16	460	M24	16	470	M24	12	476.2	42	62	55	75
400	355	305	390	102	376	60	40	12	150	125	14	M20	16	495	M24	16	515	M27	16	525	M27	16	539.7	76	90	94	104
450	400	343	444	114	430	60	45	12	175	140	18	M20	16	550	M24	20	565	M27	20	585	M27	16	577.8	110	170	135	195
500	422	366	495	127	479	60	45	12	210	165	22	M20	20	600	M24	20	620	M30	20	650	M27	20	635.0	140	180	165	205
600	495	460	595	154	575	75	60	18	210	165	22	M24	20	705	M27	20	725	M33	20	770	M33	20	749.3	220	290	220	290
700	550	506	690	165	670	90	70	20	300	254	18	M24	24	810	M27	24	840	M33	24	840	M33	28	863.6	300	415	300	415
800	640	590	780	190	757	100	80	22	300	254	18	M27	24	920	M30	24	950	M36	24	950	M39	28	977.9	444	570	465	570

BFKI/BFPD - Double Flange

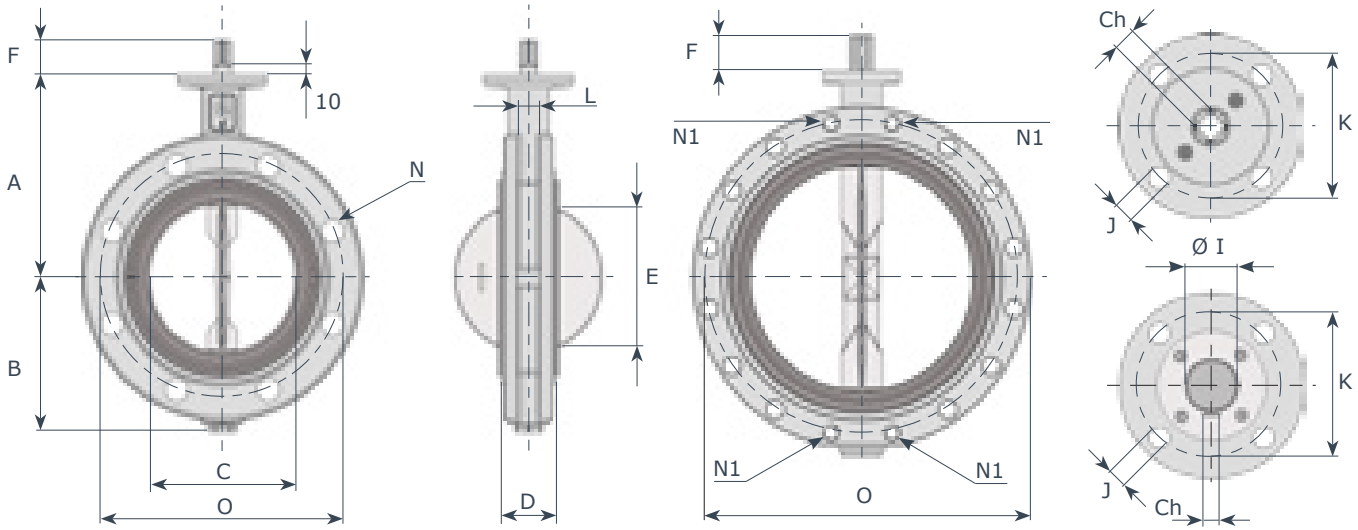

Upper flange - ISO 5211

DN 80 - 150 F07 - 4 holes
 DN 200 - 300 F10 - 4 holes

DN 350 - 400
 DN 450
 DN 500 - 600

F12 - 4 holes
 F14 - 4 holes
 F16 - 4 holes

Note: in case of ANSI150 flanges, threading can be: 16"÷24" ANSI B1.1-8 UNC2B

DN	"	A	B	C	D	E	F	Ø I	Ch	K	J	L	PN 6				PN 10				PN 16				ANSI 150				Kg.
													N	N1	n.	O	N	N1	n.	O	N	N1	n.	O	N	N1	n.	O	
80	3	158	110	81	46	67	34	14	11	70	9	14	18	--	4	150	18	--	8	160	18	--	8	160	18	--	4	152.4	6.5
100	4	173	128	101	52	87	34	16	11	70	9	16	18	--	4	170	18	--	8	180	18	--	8	180	18	--	8	190.5	8
150	6	202	155	150	56	140	34	18	14	70	9	18	18	--	8	225	22	--	8	240	22	--	8	240	22	--	8	241.3	12
200	8	240	190	200	60	191	38	22	17	102	11	22	18	--	8	280	22	--	8	295	22	--	12	295	22	--	8	298.4	20
250	10	270	220	250	68	241	38	30	22	102	11	30	18	--	12	335	22	--	12	350	25	--	12	355	25	--	12	361.9	30
300	12	300	247	298	78	289	38	30	22	102	11	30	22	--	12	395	22	--	12	400	25	--	12	410	25	--	12	431.8	46
350	14	330	285	341	78	332	60	35	10	125	14	35	22	--	12	445	22	--	16	460	25	--	16	470	28	--	12	476.2	65
400	16	355	310	390	102	376	60	40	12	125	14	40	22	M20	16	495	25	M24	16	515	30	M27	16	525	30	M27	16	539.7	85
450	18	400	343	444	114	430	60	45	12	140	18	45	22	M20	16	550	25	M24	20	565	30	M27	20	585	30	M27	16	577.8	120
500	20	422	375	495	127	479	60	45	12	165	22	45	22	M20	20	600	25	M24	20	620	33	M30	20	650	30	M27	20	635.0	180
600	24	495	460	595	154	575	75	60	18	165	22	60	25	M24	20	705	30	M27	20	725	36	M33	20	770	36	M33	20	749.3	270

BVKX - Wafer BLKX - Lug

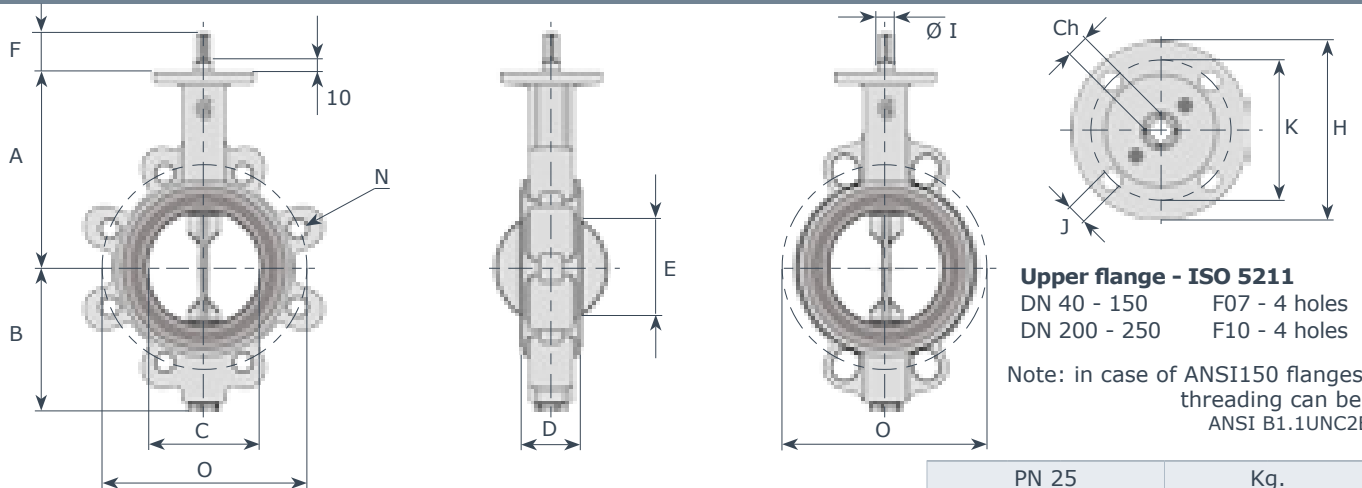

Upper flange - ISO 5211

DN 40 - 150 F07 - 4 holes
 DN 200 - 250 F10 - 4 holes

Note: in case of ANSI150 flanges, threading can be: ANSI B1.1UNC2B

DN	"	A	B	C	D	E	F	Ø I	Ch	H	K	J	PN 25			Kg.	
													N	n.	O	wafer	lug
50	2	138	81	55	43	35	34	14	11	90	70	9	M16	4	125	2.8	3.7
65	2 1/2	144	98	68	46	50	34	14	11	90	70	9	M16	8	145	3.7	5.3
80	3	158	110	81	46	67	34	14	11	90	70	9	M16	8	160	4	6.1
100	4	173	128	101	52	87	34	16	11	90	70	9	M20	8	190	6	8.1
125	5	186	140	126	56	113	34	18	14	90	70	9	M24	8	220	7.2	9.7
150	6	202	155	150	56	140	34	18	14	90	70	9	M24	8	250	9.5	11.8
200	8	240	190	200	60	191	38	22	17	125	102	11	M24	12	310	16	29
250	10	270	220	250	68	241	38	30	22	125	102	11	--	--	370	25	--

PD Series - Torque values - Nm - safety factor excluded

Seat body NBR/EPDM				fluid H ₂ O - 20°C				Seat body FKM/natural rubber				fluid H ₂ O - 20°C								
working pressure BAR								working pressure BAR												
DN	0	6	10	DN	0	6	10	DN	0	6	10	DN	0	6	DN	0	6			
80	5	7	11	200	47	58	90	400	382	405	420	80	7	11	200	62	78	400	515	540
100	8	12	24	250	89	100	115	450	395	418	445	100	11	16	250	120	134	450	578	627
125	22	31	40	300	167	180	280	500	410	430	460	125	29	42	300	225	241	500	607	675
150	40	49	45	350	245	340	395	600	1330	1577	1660	150	52	65	350	465	495	600	1795	2130

KI Series - Torque values - Nm - safety factor excluded

Seat body NBR/EPDM					fluid H ₂ O - 20°C									
working pressure BAR					working pressure BAR					working pressure BAR				
DN	0	6	10	16	DN	0	6	10	16	DN	0	6	10	16
40	11	11	13	14	150	55	60	84	90	450	480	520	720	1050
50	11	12	13	15	200	100	107	180	210	500	550	600	810	1600
65	11	16	16	18	250	160	175	220	320	600	1650	1960	2300	-
80	20	30	36	40	300	260	270	320	390	700	2270	3000	3350	-
100	40	43	45	48	350	410	450	590	850	800	3200	3400	4000	-
125	48	52	52	70	400	450	480	650	900					

Seat body FKM/natural rubber					fluid H ₂ O - 20°C									
working pressure BAR					working pressure BAR					working pressure BAR				
DN	0	6	10	16	DN	0	6	10	16	DN	0	6	10	16
40	14	14	16	17	150	66	72	101	108	450	580	630	880	1310
50	14	15	16	18	200	120	129	216	252	500	660	740	990	2020
65	14	20	20	22	250	192	210	264	386	600	1980	2380	2760	-
80	24	36	44	48	300	312	330	396	480	700	2750	3680	4040	-
100	48	52	54	58	350	498	545	728	1050	800	3880	4120	4860	-
125	60	62	64	84	400	550	584	798	1120					

KA/KX Series - Torque values - Nm - safety factor excluded

Seat body NBR/EPDM							fluid H ₂ O - 20°C						
working pressure BAR							working pressure BAR						
DN	0	6	10	16	20	25	DN	0	6	10	16	20	
40	12	12	14	15	15	-	300	272	294	362	410	429	
50	12	13	14	16	17	20	350	431	557	714	1071	1122	
65	12	17	17	19	20	31	400	683	767	893	1470	1540	
80	21	32	38	42	44	49	450	1000	1208	1313	1995	2090	
100	42	45	47	50	53	65	500	1155	1418	1733	2625	2750	
125	50	55	55	74	77	82	600	2300	2800	3700	4800	5280	
150	58	63	88	95	99	103	700	3800	5050	5600	6900	7590	
200	105	112	189	221	231	320	800	5200	6800	7900	10300	11330	
250	175	190	231	336	352	440							

Head losses

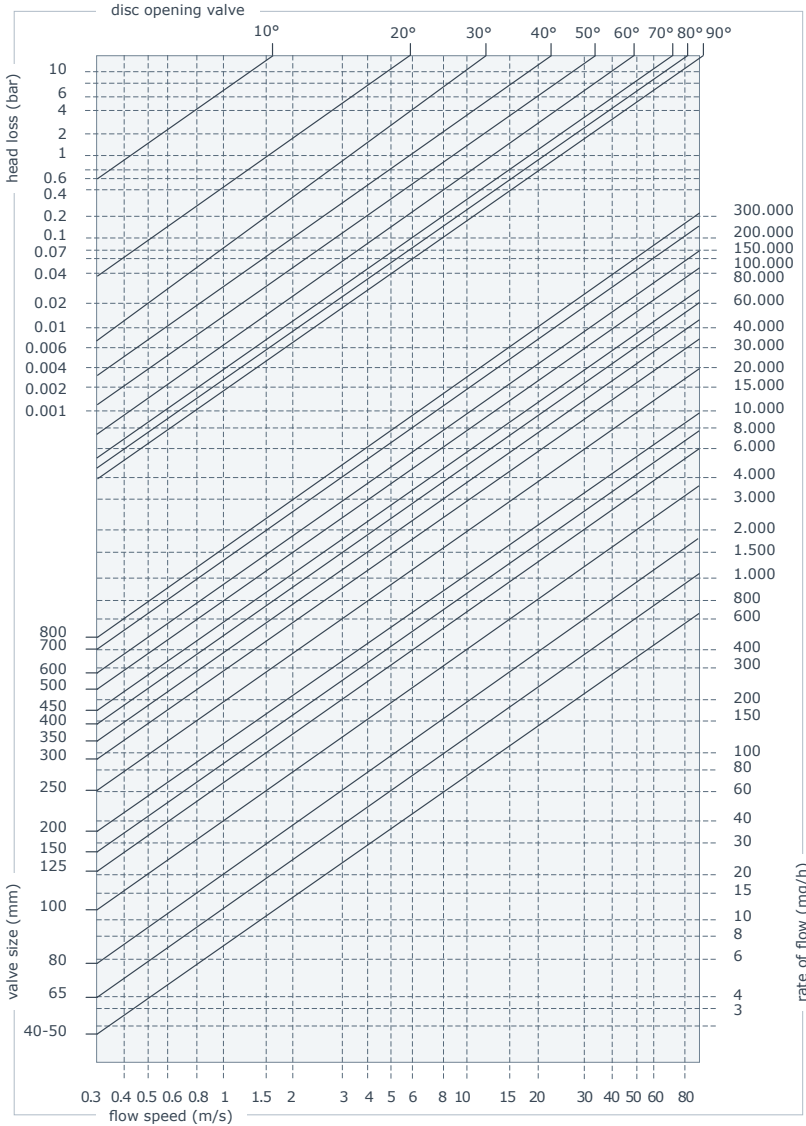

Formulae for calculation of rate flow

Liquids:
$$Q = \frac{KV}{\sqrt{\frac{PS}{\Delta P}}}$$

Q rate of flow (m³/h)
 PS specific gravity (water=1)
 ΔP pressure drop (bar)

Gas:
$$Q = 28.5 \frac{KV}{\sqrt{\frac{PS}{P_2 \cdot \Delta P}}}$$

Q rate of flow (m³/h)
 PS specific gravity (air=1)
 ΔP pressure drop (bar) (less than 1/2 inlet pressure)
 P₂ outlet pressure

Steam:
$$Q = 22.5 \cdot KV \cdot \sqrt{P_2 \cdot \Delta P}$$

Q rate of flow (Kg/h)
 ΔP pressure drop (bar) (less than 1/2 inlet pressure)
 P₂ outlet pressure

Calculation of the rate of flow equivalent to H₂O:

$$Q_e = Q \sqrt{\frac{d}{1000}}$$







For different liquid, gas or steam head losses are determined by equivalent water of flow, as follows:

- Q_e equivalent water flow (mc/l o l/s)
- Q fluid flow (mc/l o l/s)
- d fluid specific gravity (Kg/mc)

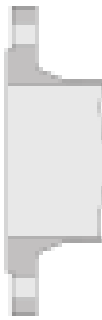
Values KV (CV = 1,16 KV)

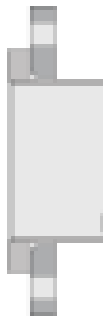
angle	40/50	65	80	100	125	150	200	250	300	350	400	450	500	600	700	800
5°	-	-	-	-	-	-	-	-	-	53	68	85	106	151	206	270
10°	-	-	-	-	-	-	-	21	49	123	161	199	246	354	482	629
15°	0,2	0,6	1,8	2,4	4,2	5,6	14	80	188	228	299	369	457	658	900	1168
20°	0,9	2,5	5,2	9,5	15	23	110	156	280	315	412	511	630	907	1234	2010
25°	3	6,1	12	22	38	61	125	225	354	457	597	740	914	1314	1789	2735
30°	6,1	11	21	39	69	112	211	310	381	661	863	1069	1320	1899	2585	5080
35°	9,9	18	33	60	105	166	303	433	521	890	1162	1440	1778	2560	3484	6254
40°	15	27	49	88	148	228	405	591	742	1184	1547	1916	2366	3407	4638	9700
45°	21	38	68	121	199	303	528	774	987	1552	2028	2512	3102	4466	6079	11581
50°	29	51	91	159	262	394	679	988	1252	2008	2620	3248	4010	5774	7860	15000
55°	39	68	119	207	338	505	863	1247	1571	2548	3318	4123	5090	7329	9976	17765
60°	53	90	156	269	434	641	1085	1591	2059	3225	4202	5218	6442	9277	12627	22200
65°	72	121	209	357	565	820	1364	2065	2807	3983	5196	6445	7957	11457	15595	26077
70°	92	161	283	487	768	1097	1788	2715	3744	5195	6775	8412	10377	14944	20341	34500
75°	109	209	381	662	1059	1507	2425	3625	4935	6964	9084	11269	13912	20032	27267	39546
80°	115	240	457	815	1303	1861	3043	4768	6831	9301	12142	15048	18578	26752	36413	47560
85°	115	253	502	906	1457	2008	3642	4890	8230	10280	13408	16632	20533	29568	40246	52566
90°	116	257	508	925	1492	2168	3838	5010	9233	10792	14082	17840	22024	31715	43166	56381

Flanges to be used

 <p>EN1092-1 Tipo 11</p> <p>UNI 2280/81 2282/67</p> <p>DIN 2631 2632 2633</p> <p>A150 B16.5 welding neck</p>	 <p>EN1092-1 Tipo 01</p> <p>UNI 2276/77 2278/67</p> <p>DIN 2575 2576 2577</p> <p>A150 B16.5 slip on</p>	 <p>EN1092-1 Tipo 02/32</p> <p>UNI 6088/89 6090</p> <p>DIN 2641 2642 2643</p>	 <p>EN1092-1 Tipo 04/34</p> <p>UNI 2289/90 2291</p> <p>DIN 2672 2673 2674</p>	 <p>EN1092-1 Tipo 02/33</p> <p> NOTE: only valves with vulcanized seat (KA/KX) are recommended with these flanges</p>
--	---	---	--	--

Bolts and rods dimensions

DN	Wafer valves											
	PN 6			PN 10			PN 16			ANSI 150		
	Bolts	Rods	N°	Bolts	Rods	N°	Bolts	Rods	N°	Bolts	Rods	N°
40	M12x80	M12x90	4	M16x90	M16x100	4	M16x90	M16x100	4	M14x90	M14x110	4
50	M12x90	M12x100	4	M16x100	M16x120	4	M16x100	M16x120	4	M16x100	M16x130	4
65	M12x100	M12x110	4	M16x110	M16x130	8	M16x110	M16x130	8	M16x110	M16x140	4
80	M16x100	M16x120	4	M16x110	M16x130	8	M16x110	M16x130	8	M16x120	M16x150	4
100	M16x110	M16x120	4	M16x120	M16x140	8	M16x120	M16x140	8	M16x120	M16x150	8
125	M16x120	M16x140	8	M16x120	M16x150	8	M16x120	M16x150	8	M20x130	M20x160	8
150	M16x120	M16x140	8	M20x130	M20x160	8	M20x130	M20x160	8	M20x140	M20x160	8
200	M16x130	M16x150	8	M20x140	M20x170	8	M20x140	M20x170	12	M20x150	M20x170	8
250	M16x140	M16x160	12	M20x150	M20x180	12	M24x150	M24x180	12	M22x160	M22x190	12
300	M20x150	M20x180	12	M20x160	M20x190	12	M24x160	M24x190	12	M22x170	M22x210	12
350	M20x150	M20x180	12	M20x160	M20x190	16	M24x170	M24x200	16	M24x180	M24x220	12
400	M20x180	M20x210	16	M24x190	M24x220	16	M27x210	M27x240	16	M27x210	M27x250	16
450	M20x190	M20x220	16	M24x200	M24x230	20	M27x220	M27x250	20	M27x230	M27x270	16
500	M20x210	M20x240	20	M24x210	M24x240	20	M30x240	M30x280	20	M27x250	M27x290	20
600	M24x240	M24x270	20	M27x250	M27x290	20	M33x270	M33x320	20	M33x290	M33x340	20
700	M24x250	M24x280	24	M27x260	M27x310	24	M33x280	M33x330	24	M33x350	M33x400	28
800	M27x280	M27x320	24	M30x290	M30x350	24	M36x320	M36x360	24	M39x400	M33x460	28

DN	Lug valves - Double Flange valves							
	PN 6		PN 10		PN 16		ANSI 150	
	Bolts	N°	Bolts	N°	Bolts	N°	Bolts	N°
40	M12x30	8	M16x30	8	M16x30	8	M14x30	8
50	M12x35	8	M16x35	8	M16x35	8	M16x35	8
65	M12x35	8	M16x40	16	M16x40	16	M16x40	8
80	M16x40	8	M16x40	16	M16x40	16	M16x40	8
100	M16x40	8	M16x40	16	M16x40	16	M16x45	16
125	M16x45	16	M16x45	16	M16x45	16	M20x50	16
150	M16x45	16	M20x45	16	M20x45	16	M20x50	16
200	M16x50	16	M20x50	16	M20x50	24	M20x55	16
250	M16x55	24	M20x55	24	M24x55	24	M22x60	24
300	M20x60	24	M20x60	24	M24x60	24	M22x60	24
350	M20x60	24	M20x60	32	M24x65	32	M24x65	24
400	M20x70	32	M24x70	32	M27x70	32	M27x80	32
450	M20x80	32	M24x80	40	M27x80	40	M27x80	32
500	M20x80	40	M24x80	40	M30x80	40	M27x90	40
600	M24x90	40	M27x90	40	M33x100	40	M33x100	40
700	M24x100	48	M27x100	48	M33x110	48	M33x130	56
800	M27x110	48	M30x120	48	M36x130	48	M39x150	56

NOTE 1: Screw and rod dimensions have been calculated with WELDING NECK flanges PN 6/10/16 (EN1092-1 Tipe 11) ANSI150 (ANSI B16.5)

NOTE 2: Number of nuts should be double when WAFER valves are assembled with threaded rods.

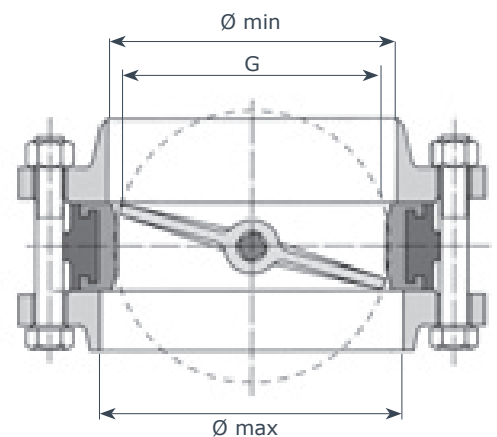

DN	40	50	65	80	100	125	150	200	250	300	350	400	450	500	600	700	800
G	36	35	50	67	87	113	140	191	241	289	332	376	430	475	575	670	757
Ø min	46	44	60	75	98	122	148	196	244	296	342	378	440	485	585	681	782
Ø max	49	62	80	93	118	146	175	225	275	330	372	422	450	500	600	717	815

Compatibility flanges - body Wafer

DN	EN 1092-1 / EN 1092-2					ASME/ANSI			BS 10		JIS B2220		
	PN 6	PN 10	PN 16	PN 25	PN 40	class 125	class 150	class 300	tab D	tab E	5K	10K	16K
40	☐	✓	✓	✓	✓	✓	✓	●	✓	✓	✓	✓	✓
50	☐	✓	✓	✓	✓	✓	✓	●	●	●	●	☐	✗
65	☐	✓	✓	✓	✓	✓	✓	●	●	●	✓	✓	☐
80	☐	✓	✓	✓	✓	✓	✓	●	●	●	●	●	✓
100	☐	✓	✓	●	●	✓	✓	✗	●	✓	✗	●	✓
125	☐	✓	✓	● (1)	● (1)	✓	✓	✗	✓	✓	☐	✓	● (1)
150	☐	✓	✓	● (1)	● (1)	✓	✓	✗	●	●	☐	✓	✗
200	☐	✓	✓	✓ (2)	✗	✓	✓	✗	✓	✓	●	●	✓ (2)
250	☐	✓	✓	●	✗	✓	✓	✗	✗	✓	●	✓	✗
300	☐	✓	✓	✓ (2)	✗	✓	✓	✗	✓	✓	●	●	✓ (2)
350	☐	✓	✓	●	✗	✓	✓	✗	✓	✓	●	●	●
400	☐	✓	✓	●	✗	✓	✓	✗	✗	✗	●	●	✓
450	☐	✓	✓	●	✗	✓	✓	✗	✗	●	●	✓	✗
500	☐	✓	✓	●	✗	✓	✓	✗	✗	✗	●	✓	✓
600	☐	✓	✓	●	✗	✓	✓	✗	✗	✗	●	✗	✗
700	☐	✓	✓	✗	✗		✓	✗			●	✓	✗
800	☐	✓	✓	✗	✗		✓	✗			●	✓	✗

✓ standard
 ☐ only body PN 6 version
 ● on request
 ✗ not possible

(1) only with ductile iron bodies
 (2) standard with ductile iron and steel bodies, on request with different materials

Compatibility flanges - body Lug

DN	EN 1092-1 / EN 1092-2					ASME/ANSI			BS 10		JIS B2220		
	PN 6	PN 10	PN 16	PN 25	PN 40	class 125	class 150	class 300	tab D	tab E	5K	10K	16K
40	☐	✓	✓	✓	✓	✓	✓	●	☐	☐	●	●	●
50	☐	✓	✓	✓	✓	✓	✓	●	●	●	●	●	✗
65	☐	✓	✓	✓	✓	✓	✓	●	●	●	●	●	●
80	☐	✓	✓	✓	✓	✓	✓	●	●	●	●	●	✓
100	☐	✓	✓	●	●	✓	✓	✗	●	✓	✗	●	●
125	☐	✓	✓	● (1)	● (1)	✓	✓	✗	✓	✓ (PN6)	✓	✓	● (1)
150	☐	✓	✓	● (1)	● (1)	✓	✓	✗	●	●	●	✓	✗
200	☐	✓	✓	●	✗	✓	✓	✗	●	●	●	●	✗
250	☐	✓	✓	✗	✗	✓	✓	✗	✗	●	●	●	✗
300	☐	✓	✓	✗	✗	✓	✓	✗	●	●	●	✓ (1)	✗
350	☐	✓	✓	✗	✗	✓	✓	✗	●	●	●	●	✗
400	☐	✓	✓	✗	✗	✓	✓	✗	●	●	●	●	●
450	☐	✓	✓	✗	✗	✓	✓	✗	✗	●	●	✓	✗
500	☐	✓	✓	✗	✗	✓	✓	✗	✗	✗	●	✓	✗
600	☐	✓	✓	●	✗	✓	✓	✗	✗	✗	●	✗	✗
700	☐	✓	✓	✗	✗		✓	✗			●	✓	✗
800	☐	✓	✓	✗	✗		✓	✗			●	✓	✗

✓ standard
 ☐ only body PN 6 version
 ● on request
 ✗ not possible

(1) only with ductile iron bodies
 (2) standard with ductile iron and steel bodies, on request with different materials

Test

GIBSON valves are built according to following international standards:

Body test pressure:	DIN 3230BA - API598	DIN 3230	body test	hydraulic test	pneu test
Hydraulic test pressure:	DIN 3230BN1 - API598	PN6	9 bar	7 bar	6 bar
Pneumatic test pressure:	DIN 3230BO1 - API598	PN10	15 bar	11 bar	6 bar
Test certificates:	UNI EN 10204 2.2 (standard)	PN16	24 bar	17,6 bar	6 bar
	UNI EN 10204 3.1 (on request)	PN25	38 bar	27,5 bar	6 bar
	UNI EN 10204 3.2 (on request)				

Test duration is indicated by API598 standard

Body test pressure:	Hydraulic test pressure:	Pneumatic test pressure:	API598	body test	hydraulic test
< DN 65 = 15 sec.	< DN 65 = 15 sec.	< DN 65 = 15 sec.	ANSI125	21 bar	18 bar
DN 65 / DN 200 = 80 sec.	DN 65 / DN 200 = 30 sec.	DN 65 / DN 200 = 30 sec.	ANSI150	30 bar	22 bar
> DN 200 = 180 sec.	> DN 200 = 60 sec	> DN 200 = 60 sec	ANSI300	78 bar	58 bar

Installation

Assembly



1 - Leave a space between flanges so that valve can be easily inserted and removed.

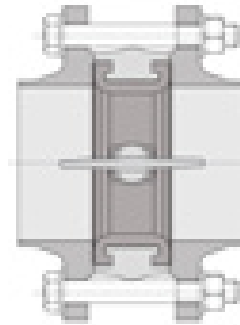

2 - Open completely the valve before tightening flanges.

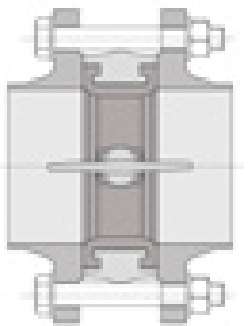

3 - Tighten bolts till flanges are in contact with valve body.

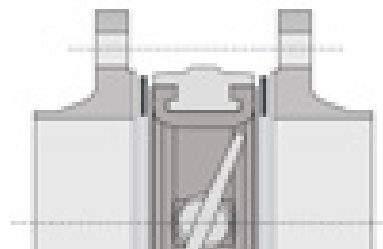

4 - NOTE: do not insert other packing between flange and valve.

NOTE: Weld the pipe only in spots with the valve between flanges. Remove the valve before finishing welding to avoid that heat damage the seat. Clean carefully the welding to avoid that slags damage the seat.

Installation for powders and muddy fluids

In case of use with powders or muddy fluids, install the valve with horizontal rotation axis, to allow sediments to flow easily on opening.

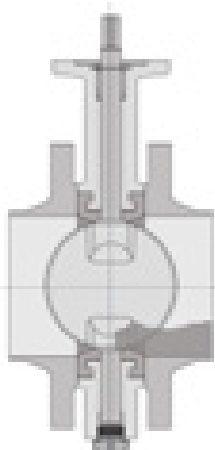

Wrong
Vertical rotation axis

←
powders or muddy fluids

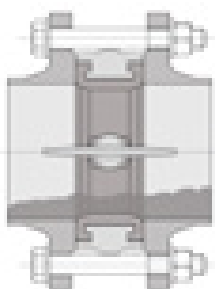

Right
Horizontal rotation axis

←
powders or muddy fluids

End piping installation

When valves are installed end of piping, a counterflange as per dwg type B is needed to secure tightness at max pressure.

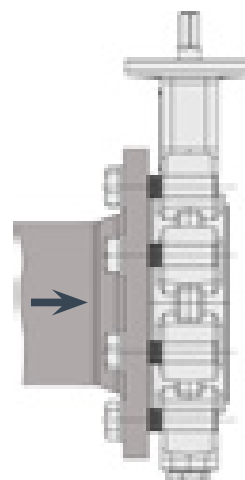

Type A installation without end piping

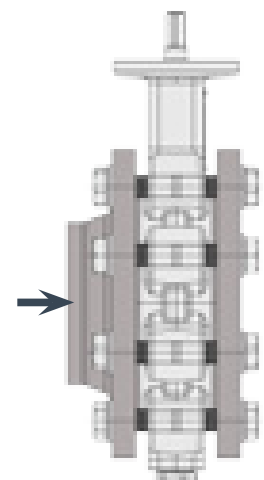

Type B installation with end piping

valve type	P _{max} (Bar)	
	type A installation	type B installation
BLPD	4	6
BLKI	6	16
BLKA	16	20
BLKX	16	25

This type of installation is always advisable with valve diameters over DN 400.

Handlevers

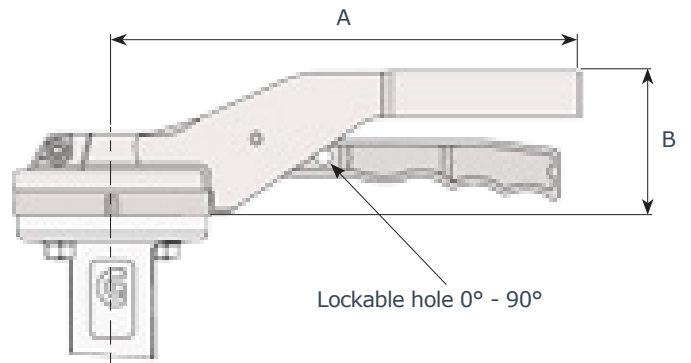

DN	A	B	D	Kg
40 - 100	220	67	93	0.6
125 - 150	275	67	93	0.65
200 - 300	340	76	125	1

Note:
DN 250 - 300 handlever not recommended
(PD series excluded)

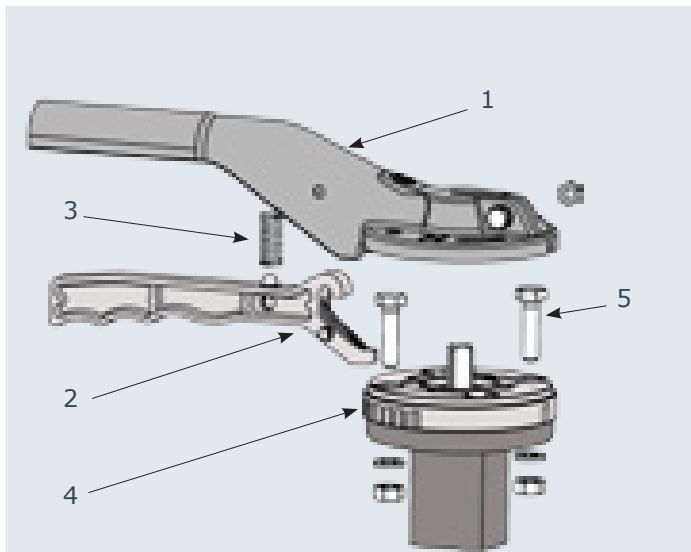
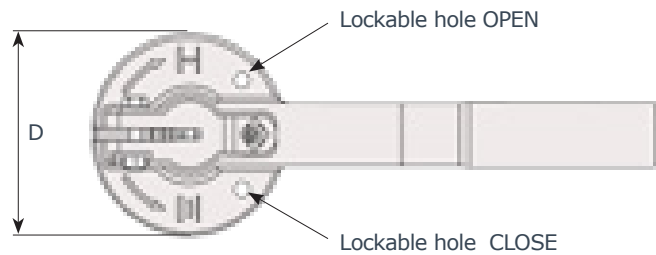

	DN40 - 300	DN40 - 150
1	lever	aluminium
2	trigger	aluminium
3	spring	stainless steel
4	disc positioning	aluminium
5	screws	stainless steel

positioning disc DN 40 - 150 designed for flanges ISO 5211 F05/F07

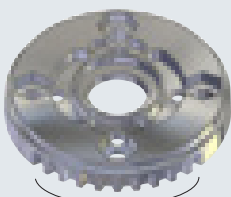

10 positions



Open - Closed

positioning disc with two types of regulation: 10 positions or Open/Close

OPTIONALS



Adjustable handlever

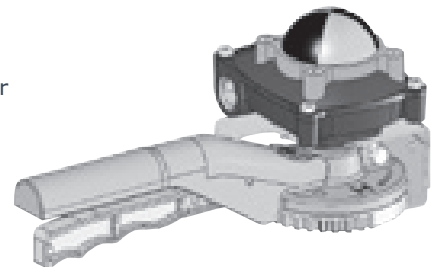

handlever with switch box
(only DN 40/150)

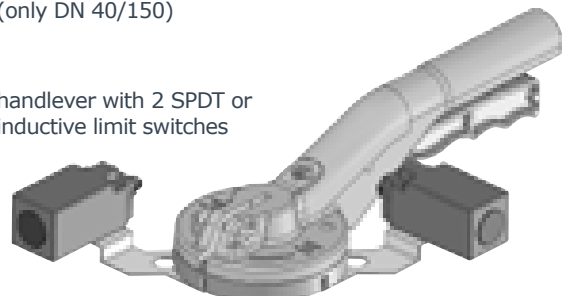

handlever with 2 SPDT or
inductive limit switches

Gearboxes

Aluminium body - HW Series

Coupling valve - actuators

DN	"	PD	KI			KA	KX
			p = 6 bar	p = 10 bar	p = 16 bar		
40	1 ^{1/2}	--	HW070	HW070	HW070	--	--
50	2	--	HW070	HW070	HW070	HW070	HW070
65	2 ^{1/2}	--	HW070	HW070	HW070	HW070	HW070
80	3	HW070	HW070	HW070	HW070	HW070	HW070
100	4	HW070	HW070	HW070	HW070	HW070	HW070
125	5	HW070	HW070	HW070	HW070	HW070	HW070
150	6	HW070	HW070	HW070	HW070	HW070	HW070
200	8	HW102	HW102	HW102	HW102	HW102	HW102
250	10	HW102	HW102	HW102	HW102	HW102	HW102
300	12	HW102	HW102	HW102	HW102	HW102	--
350	14	HW140	HW140	HW140	HW140	HW140	--
400	16	HW140	HW140	HW140	HW140	HW165	--
450	18	HW165	HW165	HW165	HW165	HW165	--
500	20	HW165	HW165	HW165	HW165	HW254	--
600	24	HW254	HW254	HW254	--	--	--
700	28	--	HW254	HW254	--	--	--
800	32	--	HW254	HW254	--	--	--

HW series

body: aluminium
 worm gears: steel
 sector gear: ductile iron
 shaft: stainless steel
 handwheel: steel
 protection: IP65
 T: -20 / +120 °C

DN	"	A
40	1 ^{1/2}	130
50	2	138
65	2 ^{1/2}	144
80	3	158
100	4	173
125	5	186
150	6	202
200	8	240
250	10	270
300	12	300
350	14	330
400	16	355
450	18	400
500	20	422
600	24	495
700	28	550
800	32	640

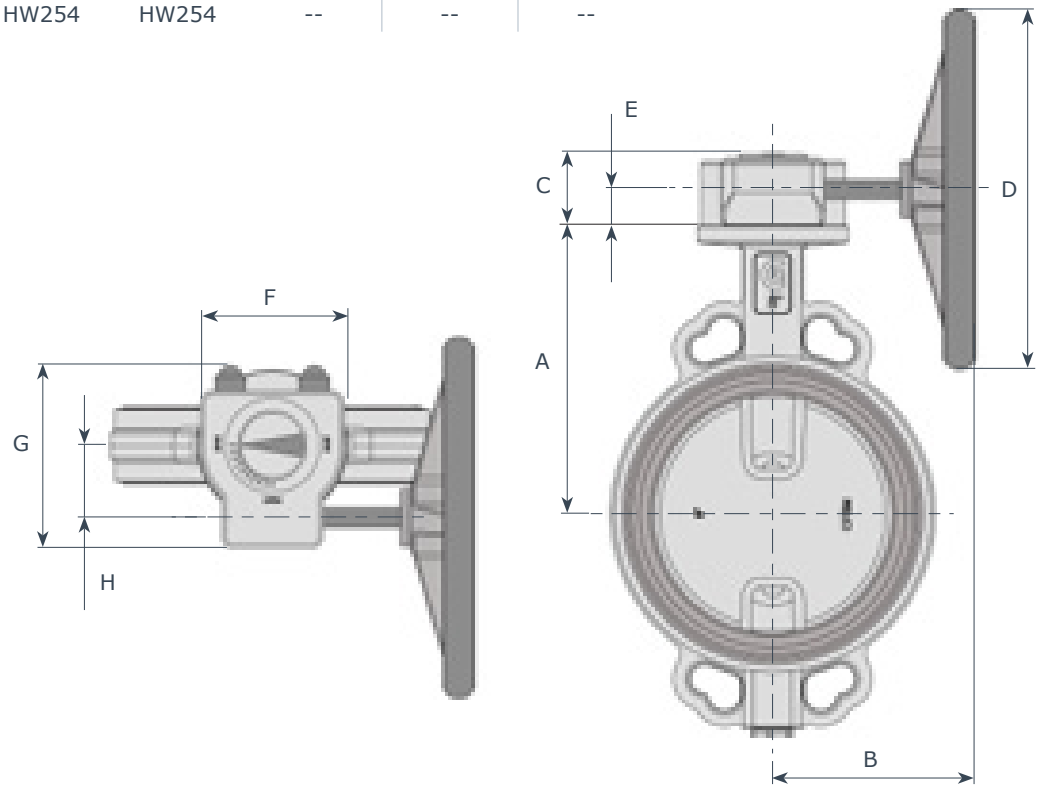

Mod.	B	C	D	E	F	G	H	Kg
HW070	165	48	140	27	80	115	42	1.6
HW102	240	56	300	33	120	150	60	3
HW140	250	95	400*	51	185	225	80	10
HW165	395	105	600	61	230	268	105	20
HW254	416	125	700	80	265	332	130	25

* for DN 350: D = 350

Gearboxes

Cast Iron body - AB Series

Coupling valve - actuators

DN	"	PD	KI			KA	KX
			p = 6 bar	p = 10 bar	p = 16 bar		
40	1 ^{1/2}	--	AB150	AB150	AB150	AB150	AB150
50	2	--	AB150	AB150	AB150	AB150	AB150
65	2 ^{1/2}	--	AB150	AB150	AB150	AB150	AB150
80	3	AB150	AB150	AB150	AB150	AB150	AB150
100	4	AB150	AB150	AB150	AB150	AB150	AB150
125	5	AB150	AB150	AB150	AB150	AB150	AB150
150	6	AB150	AB150	AB150	AB150	AB150	AB150
200	8	AB215	AB215	AB215	AB215	AB215	AB215
250	10	AB550	AB550	AB550	AB550	AB550	AB550
300	12	AB550	AB550	AB550	AB550	AB550	--
350	14	AB880	AB880	AB880	AB880	AB880	--
400	16	AB880	AB880	AB880	AB880	AB880	--
450	18	AB880	AB880	AB880	AB880	AB1250	--
500	20	AB880	AB880	AB880	AB880	AB1250	--
600	24	AB1250	AB1250	AB1250	--	AB1954	--
700	28	--	AB1950	AB1950	--	AB6804	--
800	32	--	AB1950	AB1954	--	AB6806	--

AB series

body: ductile iron
 worm gears: steel
 sector gear: ductile iron
 shaft: steel
 handwheel: steel
 protection: IP67
 T: -20 / +120 °C
 low/high temperature execution on request

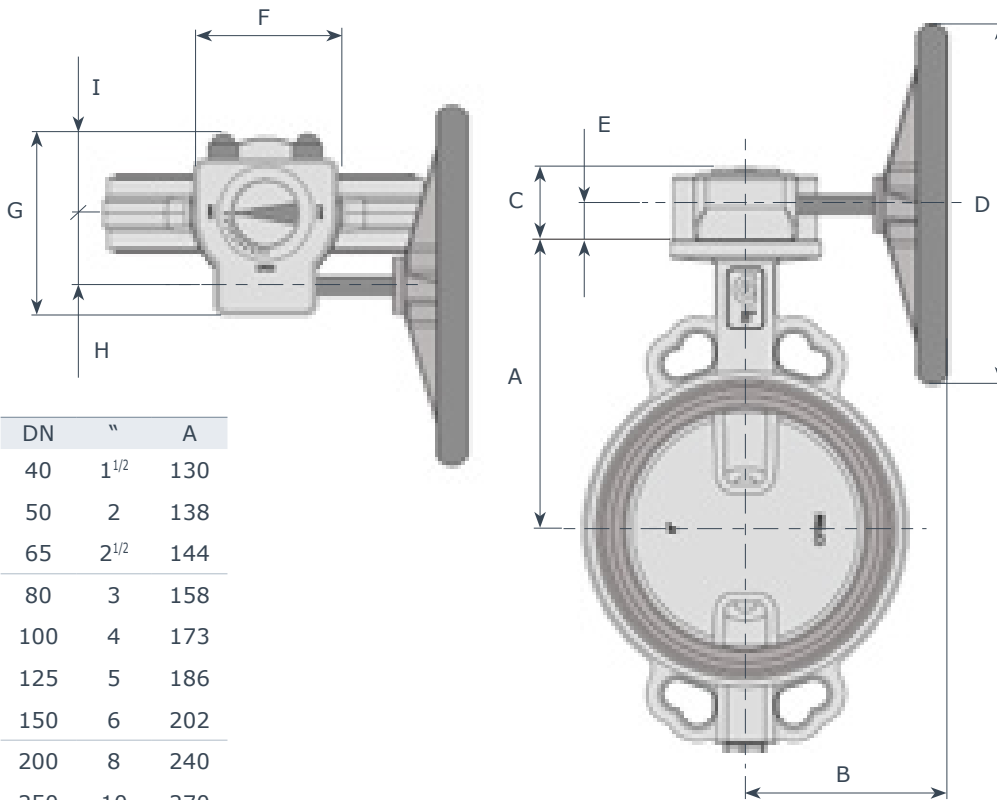

DN	"	A
40	1 ^{1/2}	130
50	2	138
65	2 ^{1/2}	144
80	3	158
100	4	173
125	5	186
150	6	202
200	8	240
250	10	270
300	12	300
350	14	330
400	16	355
450	18	400
500	20	422
600	24	495
700	28	550
800	32	640

Mod.	B	C	D	E	F	G	H	I	Kg
AB150	157.5	55	200	27	80	124	43	58	2.2
AB215	217	63	200	29	102	128	52	48	3.5
AB550	282	88	300	41	138	174	71	69	8.5
AB880	282	93	400	42	200	226	86	100	14
AB1250	322	102	500	48	220	258	105	110	22
AB1950	425	126	600	55	285	323	130	143	32
AB1954	398	126	600	55	285	323	130	143	39
AB6804	451	159	600	59	370	407	182	170	62.5
AB6806	451	159	600	59	370	407	182	170	64.2

Waterproof valve shaft extension

When necessary, it's possible to extend the valve shaft as indicated in the figure. Construction is in carbon steel with protective paint (on request stainless steel).

"L" measure should be indicated when ordering.

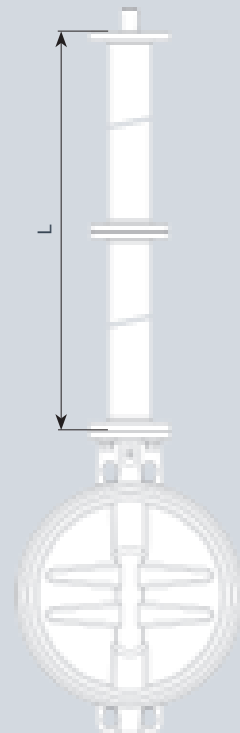

Our technical department is available to solve special applications.



MORE THAN 30 YEARS OF HIGH QUALITY EXPERIENCE

Ghibson Italia can now boast of more than 30 years of experience in manufacturing of industrial valves.

In these 30 years we have designed and manufactured in our facilities in Italy butterfly valves and check valves, for the most different industrial applications.

We export our products all over the world always providing our customers with the best assistance during all the phases: design, installation, maintenance.

MARKET SEGMENTS

Marine
Water Treatment
Pulp & Paper
Power Plant
Nuclear Plant
HVAC
Chemical & Petrochemical
Powder Conveying Systems
Food & Beverage

APPLICATIONS

Steam isolation - Vacuum service - Refining
Cooling Water systems - Metallurgical processes
Powder transportation & storage
Oil field recovery - Liquid natural gas
Steam service - Steam Turbine
Saltwater Service - District heating & cooling
Hot Air & Smokes
Chemicals storage & transportation
Food & Beverage processes

DEPARTMENTS

- RESEARCH & DEVELOPMENT
- DESIGN
- CUSTOMIZATION
- PRODUCTION & LOGISTIC
- SALES & MARKETING
- QUALITY CONTROL
- CERTIFICATIONS
- PACKING AND SHIPPING
- AFTER SALES SUPPORT

WIDE RANGE OF PRODUCTS

Very large choice of materials including valves of every alloy of carbon or stainless steel, bronze, aluminium, as well as with PTFE or Polypropylene.

We manufacture rubber seated valves with many elastomer types (EPDM, NBR, FKM, Silicone, Carboxidate among others), as well as PTFE, RTFE seated valves with many different coatings such as Halar, Rilsan, PFA, Chenisil, etc.

We can offer a total assistance:

- before selling we can start from dimensioning the valves and actuators, make selection of materials for all parts upon knowing the specification, prepare all types of drawings etc.
- after selling we make final documentation, provide installation supervision, undertake commissioning etc.

BUTTERFLY VALVES

Rubber Seated
PTFE Seated
High Performance
Damper Valves

ACTUATORS & OPTIONS

Pneumatic - Electric - Hydraulic

CONTROL SYSTEMS

CUSTOMIZED VALVES

CHECK VALVES

Disc type
Swing type
Dual plate

CERTIFICATIONS

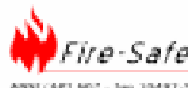



G **GHIBSON** valves

*not just valves,
but solutions*

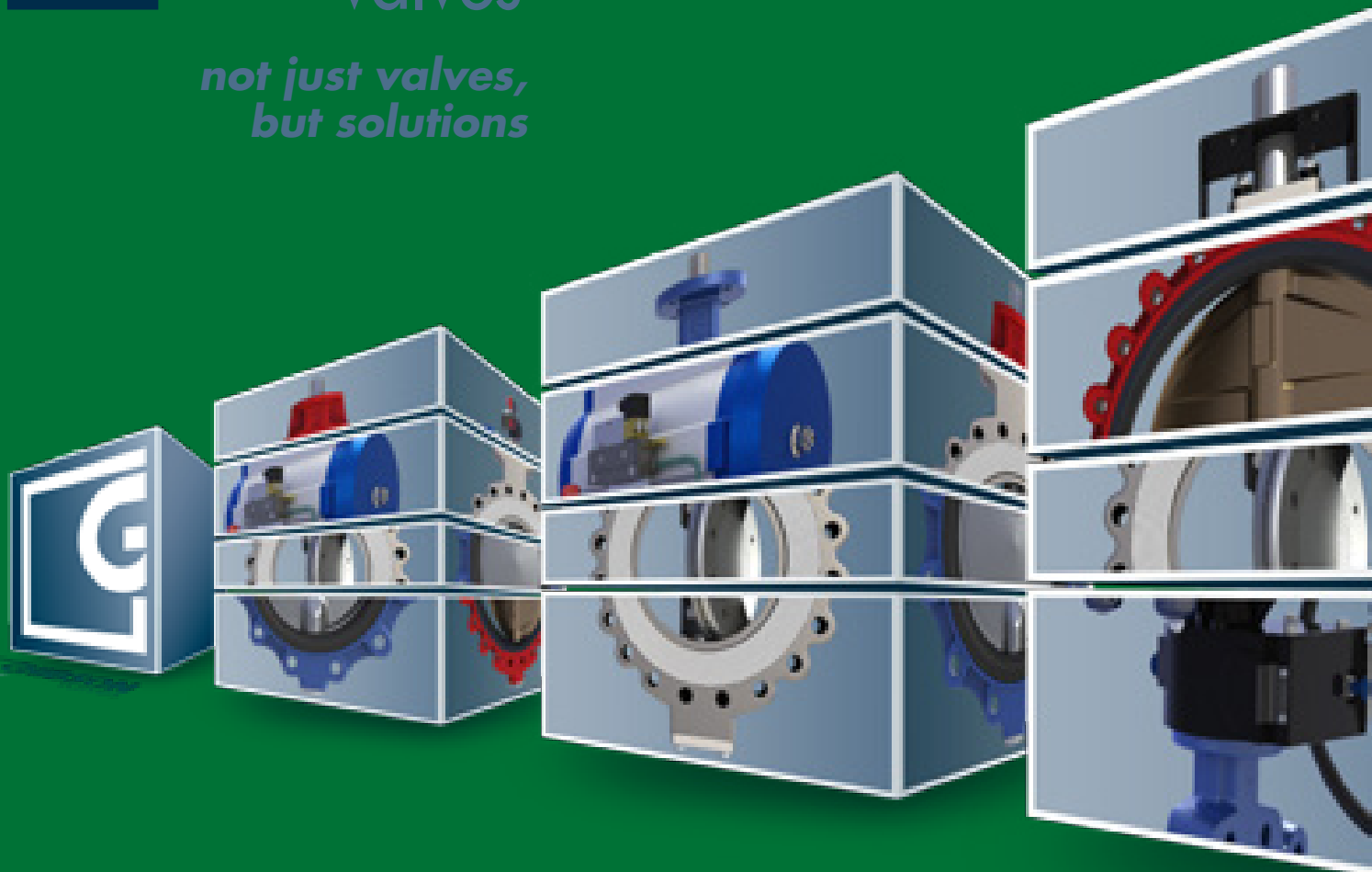

armakom DYSTRYBUTOR W POLSCE

ARMAKOM ul. Zmudzka 31 85-028 Bydgoszcz

tel +48 52 3456011

fax +48 52 3456021

www.armakom.pl info@armakom.pl