

BIDIRECTIONAL KNIFE GATE VALVE

- Bidirectional knife gate valve.
- Valve suitable for use as end-of-line.
- Monobloc cast iron body.
- Stainless steel through-conduit gate. Two rubber sleeves.
- Provides high flow rates with low pressure drops.
- Various seat materials available.
- Face-to-face distance in accordance with CMO standard.

General applications:

-This knife gate valve is suitable for working in the mining industry, in loaded fluid transport lines such as water with stones, sludge, etc, and, in general, for abrasive fluids in the chemical industry and waste water. Designed for the following applications:

- Mining
- Sewage treatment
- Electrical power stations - Chemical plants
- Energy sector
- Thermal power stations

Sizes: DN50 to DN1500 (larger sizes to order).

Working (ΔP):

	Maximum PN
DN50 to DN600	10 kg/cm ²
DN700 to DN1400	6 kg/cm ²
DN1500	2 Kg/cm ²

- The pressures indicated in the table can be used in either of the valve's two directions.

Flange borehole: DIN PN10 & ANSI B16.5 (150 LB)

Others commonly used:

DIN PN 16	JIS standard
DIN PN 6	DIN PN25
Australian Standard	British Standard

Directives:

Machinery Directive: **DIR 2006/42/EC (MACHINERY)**

Pressure Equipment Directive: **DIR 97/23/EC (PED) ART.3, P.3**

Potential Explosive Atmospheres Directive: **DIR 94/9/EC (ATEX) CAT.3 ZONE 2 and 22 GD.** For further information on categories and zones please contact the CMO Technical-Commercial Dept.

Quality dossier:-All valves are tested hydrostatically at CMO and material and test certificates can be provided.

-Body test = working pressure x 1.5.

-Seal test = working pressure x 1.1.

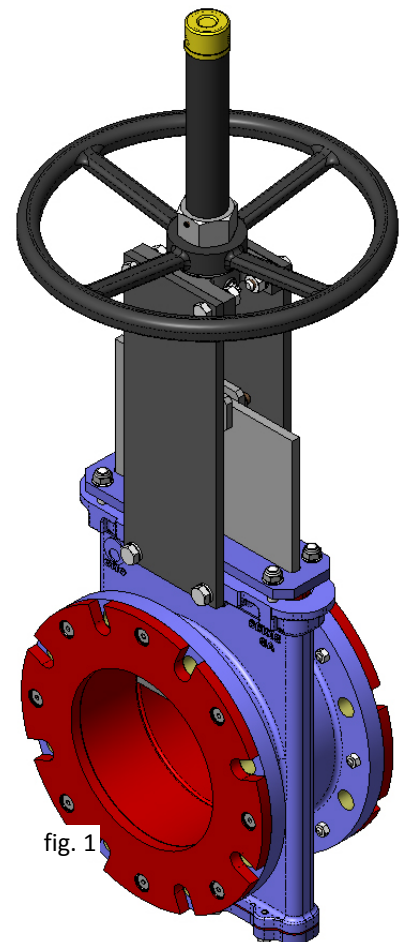

Advantages of CMO "GA Model"

- The main characteristic of this knife-gate valve is that it provides a full continuous flow. This means that in open position it produces no cavities and there is no turbulence in the fluid.
- Valve suitable for use as end-of-line.
- The **GA** valve body is a single monobloc piece.
- The stem protection hood is independent from the handwheel securing nut, this means the hood can be disassembled without the need to release the handwheel. This advantage allows regular maintenance operations to be carried out, such as lubricating the stem, etc.
- The CMO valve stem is made from stainless steel 18/8. This is another additional benefit, since some manufacturers supply it with 13% chrome, which quickly rusts.
- The operating wheel is manufactured in nodular cast GJS-500. Some manufacturers supply it in common cast-iron, which can lead to breakage in the event of very high operation torque or a bang.
- The yoke has a compact design with the bronze actuator nut protected in a sealed and lubricated box. This makes it possible to move the valve with a key, even without the handwheel (in other manufacturers' products this is not possible).
- The pneumatic actuator's upper and lower covers are made of GJS-400 nodular cast iron, making them highly shock resistant. This characteristic is essential in pneumatic actuators.
- The pneumatic cylinder sealing joints are commercial products and can be purchased worldwide. This means it is not necessary to contact CMO every time a sealing joint is required.

STANDARD COMPONENTS LIST		
COMPONENT	CAST IRON VERSION	STAINLESS STEEL VERSION
1- Body	GJS-500	CF8M
2- Gate	AISI304	AISI316
3- Packing gland	STEEL	AISI316
4- Packing seal	NATURAL RUBBER	
5- Gasket	LUBRICATED GASKET	
6 - Bottom cover	STEEL	AISI316
7- Sleeve	NATURAL RUBBER	
8- Retainer sleeve	NATURAL RUBBER	
9- Support plates	STEEL	STEEL
10- Stem	AISI303	AISI303
11- Yoke	GJS-500	GJS-500
12- Stem nut	BRONZE	BRONZE
13- Handwheel	GJS-500	GJS-500
14- Stopper nut	STEEL	STEEL
15- Hood nut	5.6 ZINC	5.6 ZINC
16- Hood	STEEL	STEEL
17- Protection cap	PLASTIC	PLASTIC

Table 1

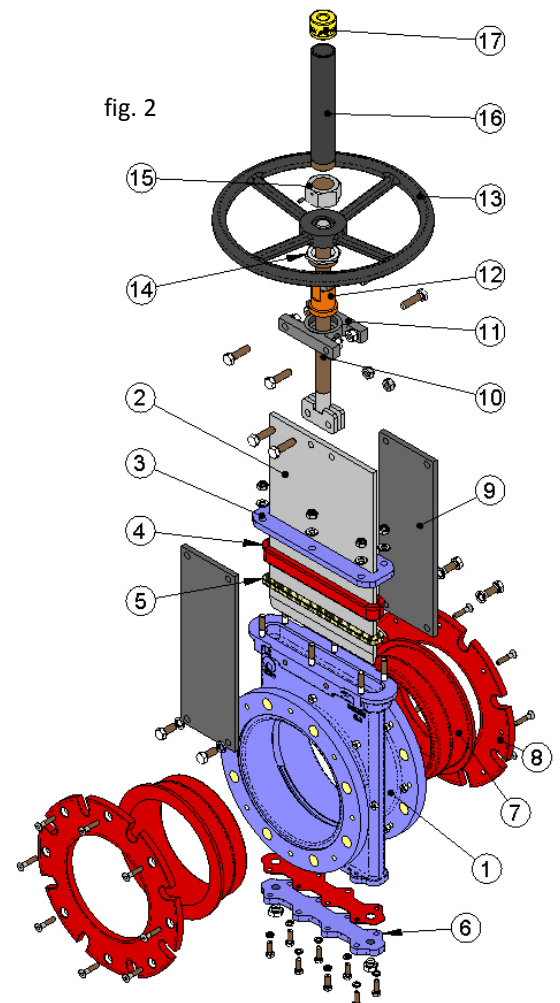

DESIGN CHARACTERISTICS

1- BODY

Reinforced monobloc cast iron body.

The body provides a full continuous flow. This means that in open position it produces no cavities and, therefore, there is no turbulence in the fluid and the load loss is minimal.

For diameters greater than DN600 the body is machine-welded with the necessary reinforcements to withstand the maximum working pressure.

Designed with full passage to provide large flows with small losses of load.

The body's internal design prevents any build-up of solids in the seal area.

The standard manufacturing materials are GJS-500 and CF8M stainless steel. Other materials such as A216WCB carbon steel and stainless steel alloys (AISI316Ti, Duplex, 254SMO, Uranus B6, Ni-Resist, Ductile Ni-Resist, etc.) are available to order. As standard, iron or carbon steel valves are painted with an anti-corrosive protection of 80 microns of EPOXY (colour RAL 5015). Other types of anti-corrosive protections are available to order.

2- THROUGH-CONDUIT GATE

The standard manufacturing materials are AISI304 stainless steel in valves with GJS-500 body, and AISI316 stainless steel in valves with CF8M body. Other materials or combinations can be supplied to order.

The through-conduit gate is polished on both sides to provide a smooth contact surface with the resilient seal. At the same time, the sharp edges on the gate are rounded to prevent the seal being cut. There are different degrees of polishing, anti-abrasion treatments and various options to adapt the valves to the customer's requirements.

3- SEAT(sealtight)

The **GA** valve seat comprises two rubber sleeves located symmetrically on each side of the body, both secured with sleeve retainers. Both the sleeve retainers and the sleeves are made of natural rubber with a metal core which helps to keep their shape and also prevent deformations. Whilst the valve is in open position, the sleeves' elasticity ensures they are joined together permanently, preventing the accumulation of solids between the two parts of the body.

The **GA** valve is designed for abrasive fluids, and, therefore, the sleeves protect the entire surface of the body which would be exposed to the abrasive flow. For easier maintenance, the sleeves can be replaced from outside the valve. It is a symmetrical two-piece seat; see the drawing of a seat (fig 3).

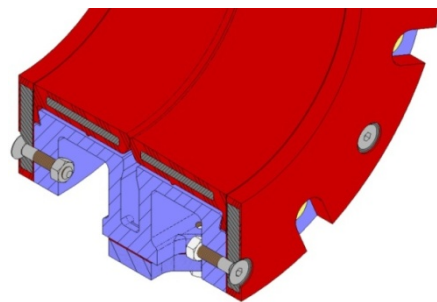

fig. 3

Sealtight materials

NATURAL RUBBER

This is the standard hermetic seal fitted in CMO **GA** model valves. It can be used in multiple applications at temperatures below 90°C with abrasive products, and it provides the valve with 100% sealtight integrity. Application: fluids in general.

KNIFE GATE VALVES

GA SERIES

EPDM

Recommended for temperatures below 90°C*. Provides the valve with 100% sealtight integrity. Application: water and acids.

NITRILE

Used in fluids containing fats or oils at temperatures no higher than 90°C*. Provides the valve with 100% sealtight integrity.

VITON

Suitable for corrosive applications and high temperatures of up to 190°C and peaks of 210°C. Provides the valve with 100% sealtight integrity.

SEAT/SEALS		
Material	Max. Temp.(°C)	Applications
Natural rubber	90	General
EPDM (E)	90*	Non-mineral oils, water and acids.
Nitrile (N)	90*	Hydrocarbons, oils and greases
Viton (V)	200	Hydrocarbons and solvents

Table 2

NOTE: More details and other materials available to order.

*→EPDM and Nitrile: possible up to max temp 120°C on request.

4- GASKET

CMO's standard gasket is composed of a specially designed EPDM O-ring which provides sealtight integrity between the body and the gate, preventing any type of leakage to the atmosphere. It also has a lubricated gasket strip to help the valve's operation during the opening and closing functions. It is located in an easily accessible place and can be replaced without dismantling the valve from the pipeline.

5- STEM

The CMO valve stem is made from stainless steel 18/8. This characteristic makes it highly resistant and provides excellent properties against corrosion.

The valve design can be rising stem or non-rising stem. When a rising stem is required for the valve, a stem hood is supplied to protect the stem from contact with dust and dirt, besides keeping it lubricated.

6- PACKING GLAND

The packing gland allows uniform force and pressure to be applied to the gasket to ensure sealtight integrity.

As standard, valves with steel body include steel packing glands, whilst valves with stainless steel body have stainless steel packing glands.

7- ACTUATORS

It is possible to supply all types of actuators, with the advantage that the CMO design is completely interchangeable. This design means customers can change the actuator themselves without any additional assembly accessories. A design characteristic of CMO valves is that all actuators are interchangeable.



KNIFE GATE VALVES

GA SERIES

Manual:

- Handwheel with rising stem
- Handwheel with non-rising stem
- Chainwheel
- Lever
- Gearbox
- Others (square stem, etc)

Automatic:

- Electric actuator
- Pneumatic cylinder
- Hydraulic cylinder

fig. 4

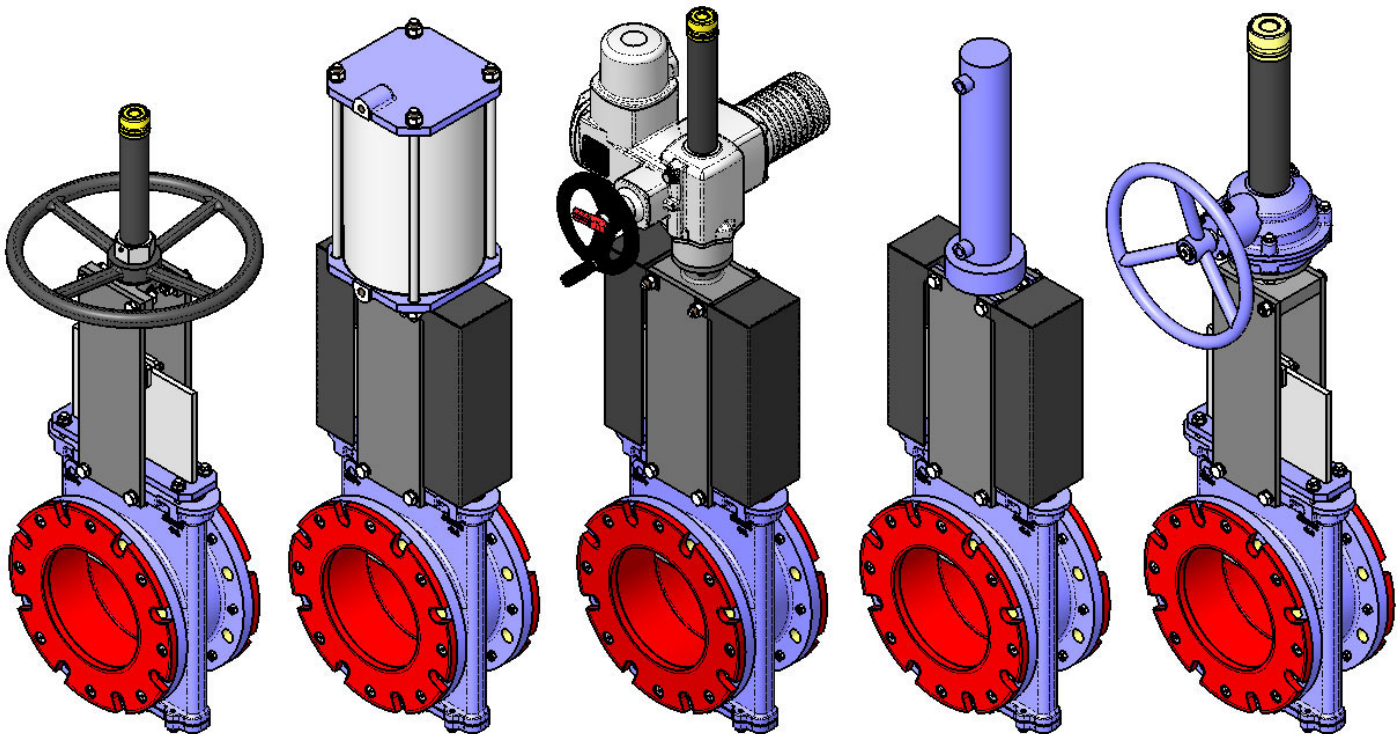

Handwheel with rising stem

Pneumatic actuator

Electric-motor actuator

Hydraulic actuator

Handwheel with gearbox

fig. 5

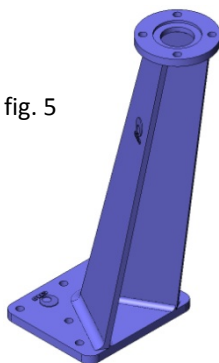

Wide range of accessories available:

- Mechanical stoppers
- Locking devices
- Emergency manual actuators
- Electrovalves
- Positioners
- Limit switches
- Proximity detectors
- Straight floor stand (fig. 6)
- Leaning floor stand (fig. 5)

fig. 6

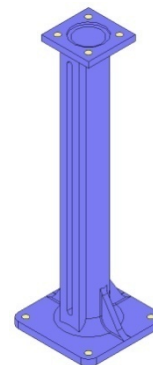

Stem extensions have also been developed, allowing the actuator to be located far away from the valve, to suit all needs. Please check with our technicians beforehand.

ACCESSORIES AND OPTIONS

Different accessories are available to adapt the valve to specific working conditions such as:

- **Mirror polished through-conduit gate:** The mirror polished through-conduit gate is especially recommended in the food industry and, as standard, in applications in which solids can stick to the gate. It is an alternative to ensure the solids slide off and do not stick to the gate.
- **PTFE coated through-conduit gate:** As with the mirror polished through-conduit gate, this improves the valve's resistance to products which can stick to the gate.
- **Stellited through-conduit gate:** Stellite is added to the inner circle of the through-conduit gate to protect it from abrasion.
- **Scraper in the gasket:** Its function is to clean the gate during the opening movement and prevent possible damage to the gasket.
- **Cased body:** Recommended in applications in which the fluid can harden and solidify inside the valve body. An external casing keeps the body temperature constant, preventing the fluid from solidifying.
- **Flushing holes in the body:** Several holes are drilled in the body to flush air, steam or other fluids out with the aim of cleaning the valve seat before sealing.
- **Electrovalves (fig. 7):** For air distribution to pneumatic actuators.
- **Junction boxes, wiring and pneumatic piping:** Units supplied fully assembled with all the necessary accessories.
- **Mechanical limit switches, inductive sensors and positioners:** Limit switches or sensors are installed to indicate precise valve position, as well as positioners to indicate continuous position (fig. 7).
- **Junction boxes, wiring and pneumatic piping:** Units supplied fully assembled with all the necessary accessories.
- **Mechanical locking device:** Allows the valve to be mechanically locked in a set position for long periods.
- **Stroke limiting mechanical stops:** Allow the stroke to be mechanically adjusted, limiting the valve run.
- **Emergency manual actuator (hand wheel/gearbox)(fig. 7):** Allows manual operation of the valve in the event of power or air failure.
- **Interchangeable actuators:** All actuators are easily interchangeable.
- **Actuator or yoke support:** Made of EPOXY-coated steel (or stainless steel to order), its robust design gives it great rigidity in order to withstand the most adverse operation conditions.
- **Epoxy coating:** All cast iron and carbon steel bodies and components in CMO valves are EPOXY coated, giving the valves great resistance to corrosion and an excellent finish. CMO's standard colour is blue, RAL-5015.
- **Through-conduit gate safety guard:** In accordance with European Safety Standards ("EC" marking), CMO automatic valves are fitted with metal guards in the gate run in order to prevent objects from being accidentally caught or dragged along.

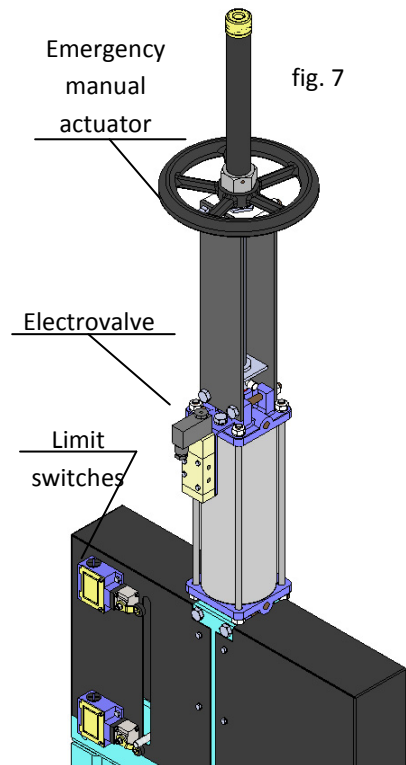

TYPES OF EXTENSION

When the valve needs to be operated from a distance, the following different types of actuators can be fitted:

1 - Extension: Floor Stand.

This extension is done by coupling a rod to the stem. The desired extension is achieved by defining the length of the rod. A floor stand is normally installed to support the actuator.

The definition variables are as follows:

- H1:** Distance from the valve shaft to the base of the stand.
- d1:** Separation from the wall to the end of the connecting flange.

Characteristics:

- Can be coupled to any type of actuator.
- A stem support-guide is recommended (fig. 8) every 1.5 m.
- The standard floor stand is 800 mm high (fig. 9). Other floor stand measurements available to order.
- Option of fitting an indicator rule in order to determine the degree of opening of the valve.
- Option of leaning floor stand (fig. 10).

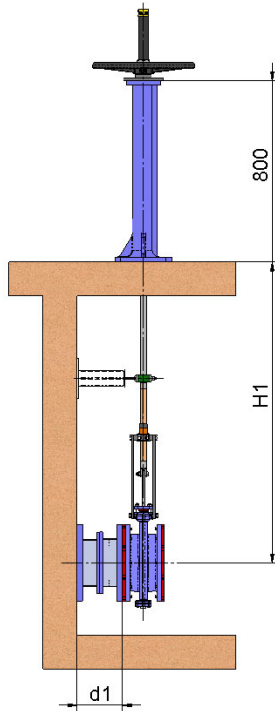

fig. 9

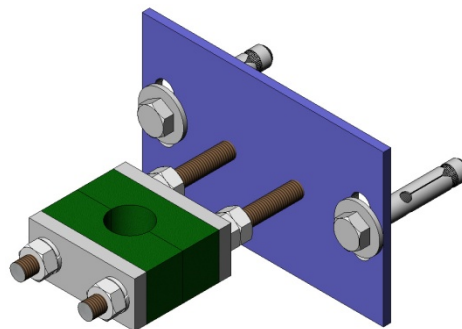

fig. 8

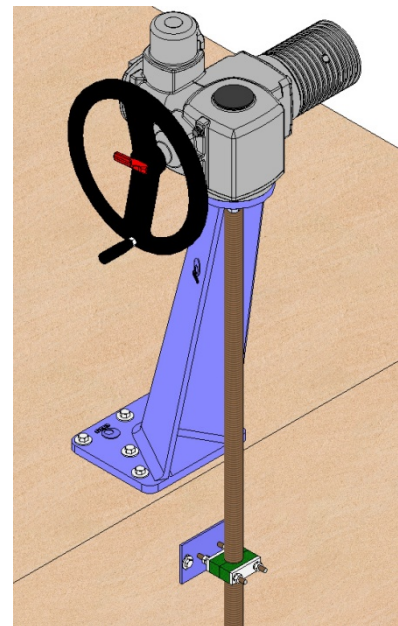

fig. 10

COMPONENTS LIST	
Component	Standard Version
Stem	AISI 303
Rod	AISI 304
Guide-support	Carbon steel with EPOXI coating
Slide	Nylon
Floor Stand	GJS-500 with EPOXY coating

Table 3



KNIFE GATE VALVES

GA SERIES

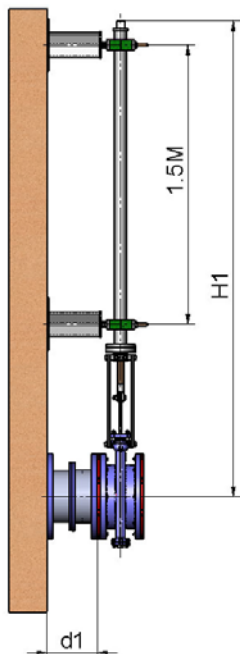

2 - Extension: Pipe (fig. 11)

This consists of raising the actuator. The pipe will rotate with the wheel or key when the valve is operated, although this will always remain at the same height.

The definition variables are as follows:

H1: Distance from the valve shaft to the required height of the actuator.

d1: Separation from the wall to the end of the connecting flange.

Characteristics:

- Standard actuators: handwheel and square stem.
- A pipe support-guide is recommended every 1.5 m.
- The standard materials are: Stainless steel or EPOXY coated carbon steel.

3 - Extension: Extended Support Plates (fig. 12)

When a short extension is required, it can be achieved by extending the support plates. An intermediate yoke can be fitted to reinforce the support plates structure.

fig. 12

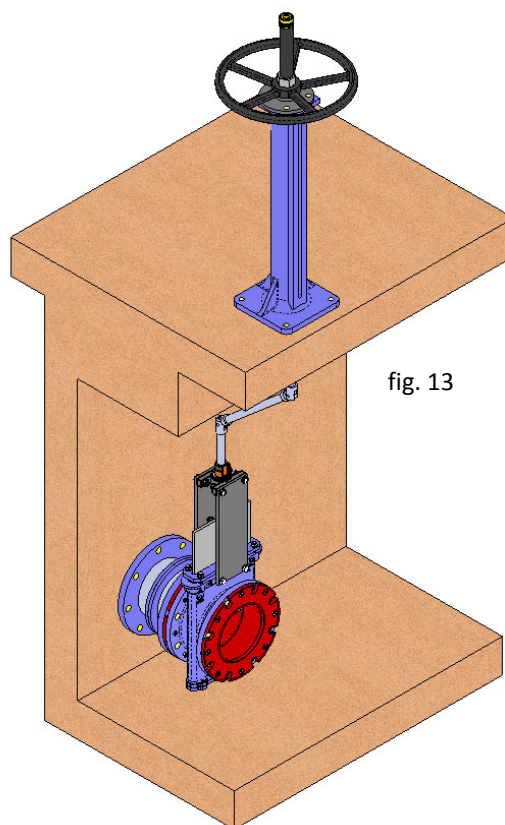
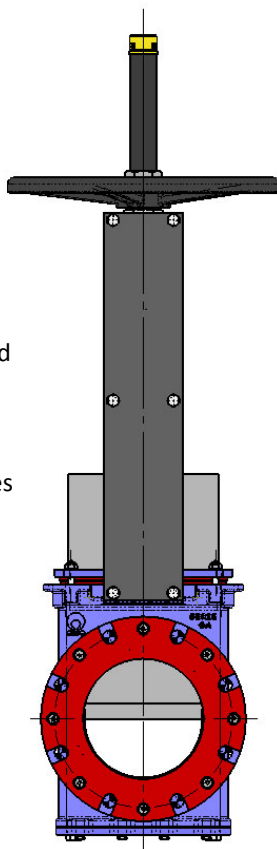

fig. 13

4 - Extension: Universal joint (fig. 13)

If the valve and the actuator are not in correct alignment, the problem can be resolved by fitting a universal joint.



KNIFE GATE VALVES

GA SERIES

HANDWHEEL with rising stem

- **B = max width** of the valve (no actuator).
- **D = max height** of the valve (no actuator).
- Options:
 - Locking devices.
 - Extensions: stand, pipe, plates, etc.
 - DN higher than those shown in the table.
- Actuator comprising:
 - Handwheel.
 - Stem.
 - Nut.
 - Stem protection hood.
- Available: DN50 to DN1000, other DN to order.
- From DN350 (inclusive) the actuator has a gearbox.

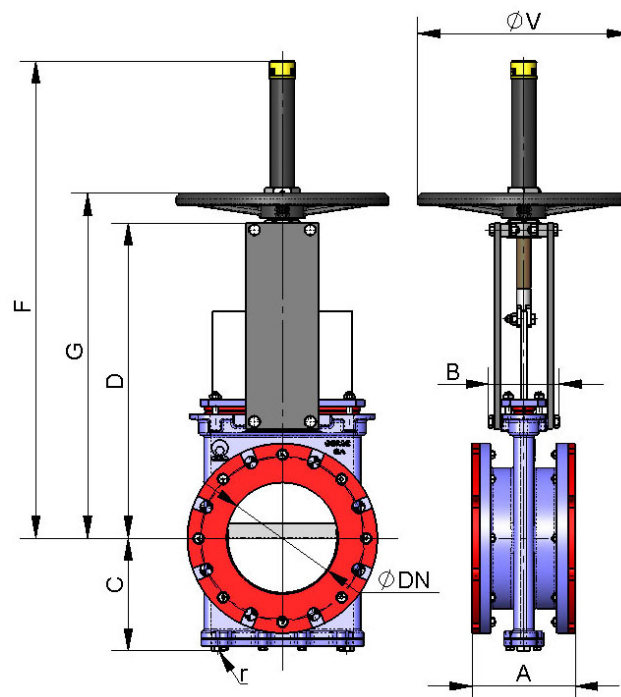

fig. 14

DN	ΔP (Kg/cm ²)	DRAFT (Nw)	TORQUE (Nm)	A	B	C	D	G	F	ϕV	r (B.S.P.)
50	10	905.21	2.06	175	109	106	280	319	449	225	1/4"
65	10	1506.9	3.48	175	109	113	306	345	500	225	1/4"
80	10	2312.5	5.28	175	109	122	332	372	551	225	1/4"
100	10	3609.8	8.24	175	109	136	368	407	587	225	1/4"
125	10	5639.4	16.1	178	126	153	421	474	713	325	1/4"
150	10	8121.1	23.18	178	126	168	466	519	757	325	1/4"
200	10	14449	41.28	184	126	199	565	618	957	325	3/8"
250	10	22591	64.54	225	197	234	626	749	1125	450	1/2"
300	10	32569	93.05	257	197	272	739	837	1213	450	1/2"
350	10	44419	172.2	257	350	297	842	942	1342	--	1/2"
400	10	58040	224.9	279	350	330	933	1033	1483	--	3/4"
450	10	73382	284.5	311	350	355	1019	1119	1619	--	3/4"
500	10	90869	496.8	359	380	391	1156	1256	1806	--	3/4"
600	10	131156	717.1	372	400	461	1338	1438	2088	--	1"
700	6	107739	589.1	378	400	534	1425	1525	2440	--	1"
750	6	129527	718	395	400	559	1520	1620	2555	--	1"
800	6	141228	772.2	411	400	584	1615	1715	2665	--	1"
900	6	179489	1164	470	400	649	1823	1923	2823	--	1"
1000	6	221406	1436	534	440	699	1992	2092	3192	--	1"

Table 4



KNIFE GATE VALVES

GA SERIES

HANDWHEEL with non-rising stem

- Suitable when no size limitations exist.
- **B = max width** of the valve (no actuator).
D = max height of the valve (no actuator).
- Options:
 - Square stem.
 - Locking devices.
 - Extensions: stand, pipe, plates, etc.
 - DN higher than those shown in the table.
- Actuator comprising:
 - Handwheel.
 - Stem.
 - Guide bushing in the yoke.
 - Nut.
- Available: DN50 to DN1000, other DN to order.
- From DN350 (inclusive) the actuator has a gearbox.

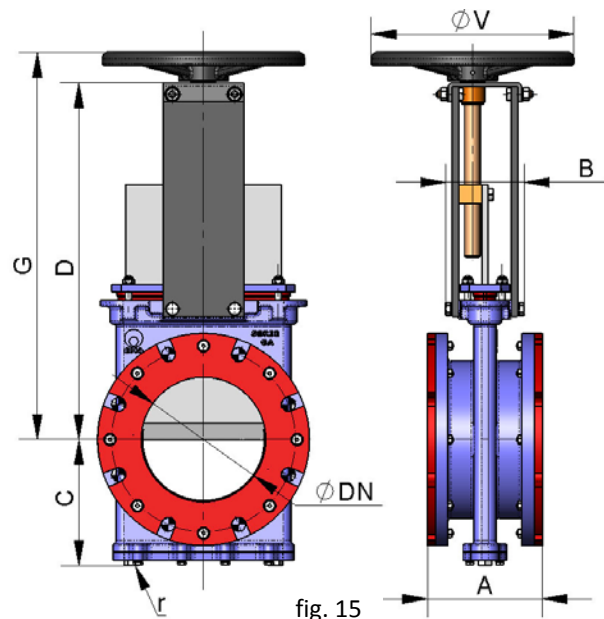

fig. 15

DN	ΔP (Kg/cm ²)	DRAFT (Nw)	TORQUE (Nm)	A	B	C	D	G	ØV	r (B.S.P.)
50	10	905.21	2.06	175	109	106	280	319	225	1/4"
65	10	1506.9	3.48	175	109	113	306	345	225	1/4"
80	10	2312.5	5.28	175	109	122	332	372	225	1/4"
100	10	3609.8	8.24	175	109	136	368	407	225	1/4"
125	10	5639.4	16.1	178	126	153	421	474	325	1/4"
150	10	8121.1	23.18	178	126	168	466	519	325	1/4"
200	10	14449	41.28	184	126	199	565	618	325	3/8"
250	10	22591	64.54	225	197	234	626	749	450	1/2"
300	10	32569	93.05	257	197	272	739	837	450	1/2"
350	10	44419	172.2	257	350	297	842	942	--	1/2"
400	10	58040	224.9	279	350	330	933	1033	--	3/4"
450	10	73382	284.5	311	350	355	1019	1119	--	3/4"
500	10	90869	496.8	359	380	391	1156	1256	--	3/4"
600	10	131156	717.1	372	400	461	1338	1438	--	1"
700	6	107739	589.1	378	400	534	1425	1525	--	1"
750	6	129527	718	395	400	559	1520	1620	--	1"
800	6	141228	772.2	411	400	584	1615	1715	--	1"
900	6	179489	1164	470	400	649	1823	1923	--	1"
1000	6	221406	1436	534	440	699	1992	2092	--	1"

Table 5

KNIFE GATE VALVES

GA SERIES

HANDWHEEL - CHAIN

Widely used in raised installations with difficult access, the handwheel is fitted in vertical position.

- **B = max width** of the valve (no actuator).
D = max height of the valve (no actuator).
- Options:
 - Locking devices.
 - Extensions: stand, pipe, plates, etc.
 - Non-rising stem.
 - DN higher than those shown in the table.
- Comprising:
 - Handwheel.
 - Stem.
 - Nut.
 - Hood.
- Available: DN50 to DN1000, other DN to order.
- From DN350 (inclusive), the valves have a gearbox, see * in the table.

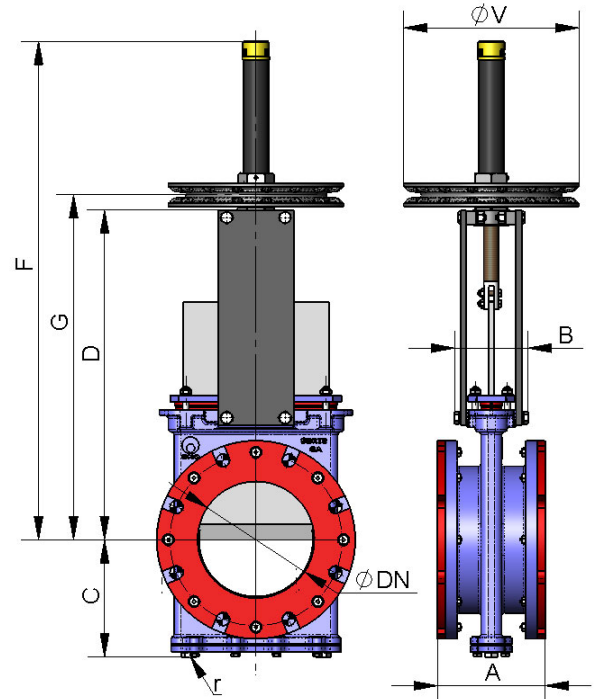

fig. 16

DN	ΔP (Kg/cm ²)	DRAFT (Nw)	TORQUE (Nm)	A	B	C	D	G	F	ϕV	r (B.S.P.)
50	10	905.21	2.06	175	109	106	280	319	449	225	1/4"
65	10	1506.9	3.48	175	109	113	306	345	500	225	1/4"
80	10	2312.5	5.28	175	109	122	332	372	551	225	1/4"
100	10	3609.8	8.24	175	109	136	368	407	587	225	1/4"
125	10	5639.4	16.1	178	126	153	421	474	713	300	1/4"
150	10	8121.1	23.18	178	126	168	466	519	757	300	1/4"
200	10	14449	41.28	184	126	199	565	618	957	300	3/8"
250	10	22591	64.54	225	197	234	626	749	1125	402	1/2"
300	10	32569	93.05	257	197	272	739	837	1213	402	1/2"
350	10	44419	172.2	257	350	297	842	942	1342	402*	1/2"
400	10	58040	224.9	279	350	330	933	1033	1483	402*	3/4"
450	10	73382	284.5	311	350	355	1019	1119	1619	402*	3/4"
500	10	90869	496.8	359	380	391	1156	1256	1806	402*	3/4"
600	10	131156	717.1	372	400	461	1338	1438	2088	402*	1"
700	6	107739	589.1	378	400	534	1425	1525	2440	402*	1"
750	6	129527	718	395	400	559	1520	1620	2555	402*	1"
800	6	141228	772.2	411	400	584	1615	1715	2665	402*	1"
900	6	179489	1164	470	400	649	1823	1923	2823	402*	1"
1000	6	221406	1436	534	440	699	1992	2092	3192	402*	1"

Table 6



KNIFE GATE VALVES

GA SERIES

LEVER

- This is a fast operation actuator.
- **B = max width** of the valve(no actuator).
D = max height of the valve(no actuator).
- The actuator includes:
 - Lever.
 - Rod.
 - Guide bushing.
 - External locking devices to hold the position.
- Available: DN50 to DN200, other DN to order.
- * Actuator designed to run at 2 Kg/cm² of differential pressure (ΔP).

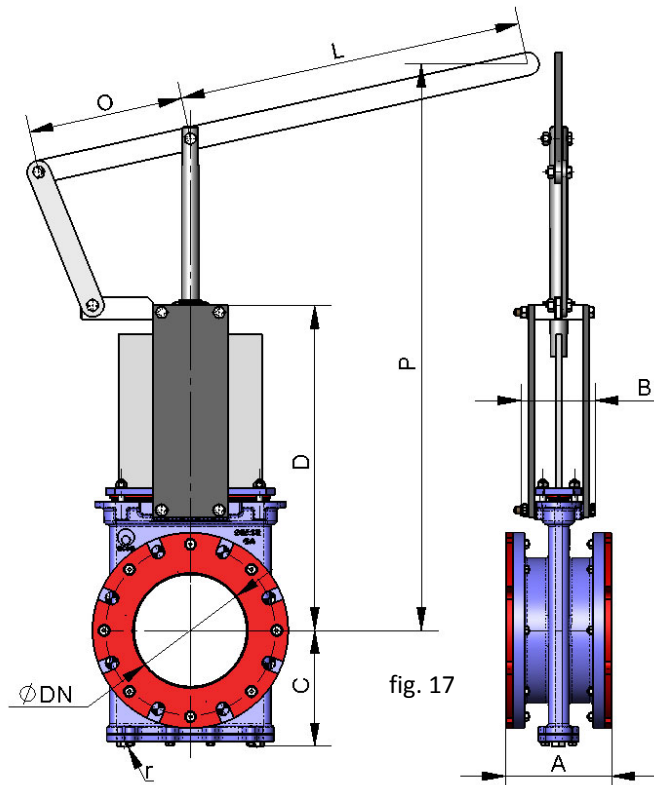

fig. 17

DN	ΔP (Kg/cm ²)	DRAFT (Nw)	A	B	C	D	P	O	L	r (B.S.P.)
50	10*	227*	175	109	106	280	426	155	325	1/4"
65	10*	382*	175	109	113	306	499	155	325	1/4"
80	10*	577*	175	109	122	332	541	155	325	1/4"
100	10*	898*	175	109	136	368	582	155	325	1/4"
125	10*	1406*	178	126	153	421	701	155	425	1/4"
150	10*	2023*	178	126	168	466	898	155	425	1/4"
200	10*	3606*	184	126	199	565	1133	290	620	3/8"

Table 7



KNIFE GATE VALVES

GA SERIES

GEARBOX

- It is recommendable for DN greater than 350.
- **B = max width** of the valve (no actuator).
D = max height of the valve (no actuator).
- Options:
 - Chainwheel.
 - Locking devices.
 - Extensions: stand, pipe, plates, etc.
 - Non-rising stem.
- Actuator comprising:
 - Stem. - Yoke.
 - Bevel gearbox. - Handwheel.
- Standard reduction ratio = 4 to 1.
- Available: DN50 to DN1500, other DN to order.

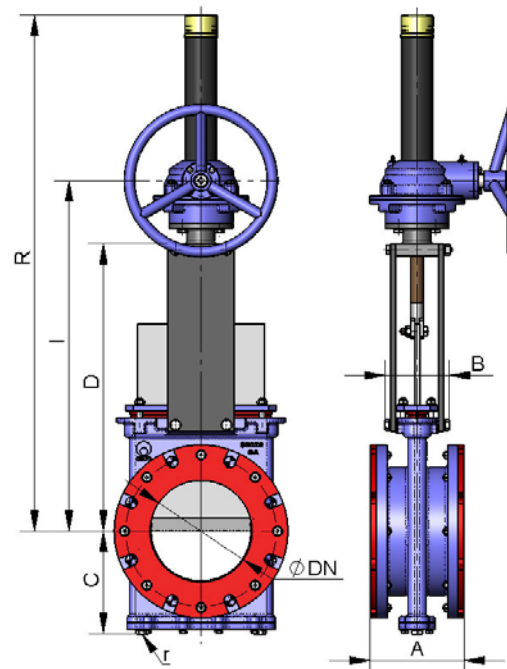

DN	ΔP (Kg/cm ²)	DRAFT (Nw)	TORQUE (Nm)	A	B	C	D	I	R	r (B.S.P.)
50	10	905.21	2.06	175	109	106	280	402	577	1/4"
65	10	1506.9	3.48	175	109	113	306	446	621	1/4"
80	10	2312.5	5.28	175	109	122	332	490	665	1/4"
100	10	3609.8	8.24	175	109	136	368	540	755	1/4"
125	10	5639.4	16.1	178	126	153	421	589	845	1/4"
150	10	8121.1	23.18	178	126	168	466	689	947	1/4"
200	10	14449	41.28	184	126	199	565	735	1103	3/8"
250	10	22591	64.54	225	197	234	626	823	1191	1/2"
300	10	32569	93.05	257	197	272	739	940	1388	1/2"
350	10	44419	172.2	257	350	297	842	1028	1570	1/2"
400	10	58040	224.9	279	350	330	933	1122	1666	3/4"
450	10	73382	284.5	311	350	355	1019	1278	1890	3/4"
500	10	90869	496.8	359	380	391	1156	1460	2172	3/4"
600	10	131156	717.1	372	400	461	1338	1610	2425	1"
700	6	107739	589.1	378	400	534	1425	1810	2750	1"
750	6	129527	718	395	400	559	1520	1845	2850	1"
800	6	141228	772.2	411	400	584	1615	1880	2950	1"
900	6	179489	1164	470	400	649	1823	1950	3150	1"
1000	6	221406	1436	534	440	699	1992	2129	3206	1"
1100	6	269251	2021	534	440	730	2217	2388	3575	1 1/2"
1200	6	321856	2416	537	480	775	2351	2522	3807	1 1/2"
1300	6	377925	3175	537	480	805	2882	3053	4482	1 1/2"
1400	6	440582	3703	533	520	875	3250	3458	4952	1 1/2"
1500	2	176037	1322	533	520	925	3695	3910	5475	1 1/2"

KNIFE GATE VALVES

GA SERIES

DOUBLE-ACTING PNEUMATIC CYLINDER

- The air supply pressure to the cylinder is a minimum of 6 Kg/cm² and a maximum of 10 Kg/cm²; the air must be dry and lubricated.
- For DN50 to DN200 valves, the cylinder's casing and covers are made of aluminium, the rod of AISI304, the piston of rubber-coated steel and the O-ring seals are made of nitrile.
- For pneumatic cylinders larger than Ø200 the covers are made of nodular cast iron or carbon steel.
- To order, the actuator can also be made from stainless steel, specifically for installation in corrosive environments.
- **B = max width** of the valve (no actuator).
D = max height of the valve (no actuator).
- Available: DN50 to DN700, other DN to order.

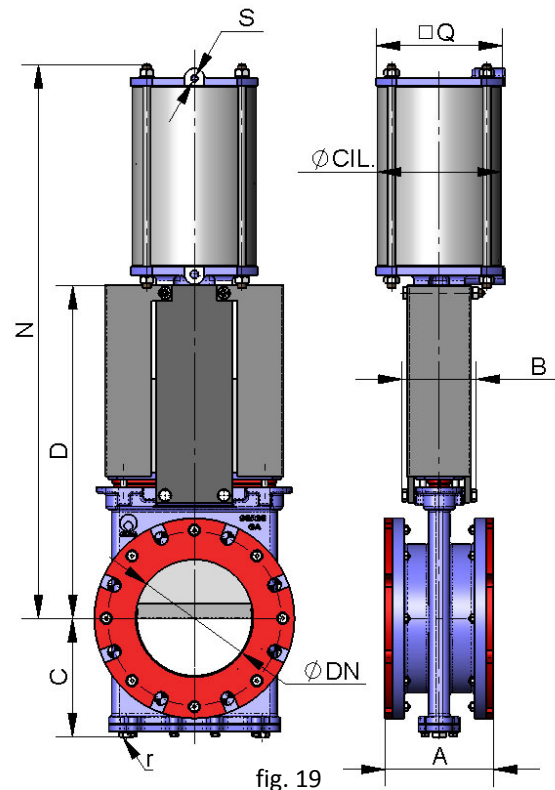

DN	ΔP (*) (Kg/cm ²)	DRAFT (Nw)	A	B	C	D	N	Q	Ø CYL.	Ø ROD	S (B.S.P.)	r (B.S.P.)
50	10	905.21	175	109	106	280	475	90	80	20	1/4"	1/4"
65	10	1506.9	175	109	113	306	515	90	80	20	1/4"	1/4"
80	10	2312.5	175	109	122	332	555	110	100	20	1/4"	1/4"
100	10	3609.8	175	109	136	368	620	135	125	25	1/4"	1/4"
125	10	5639.4	178	126	153	421	700	170	160	30	1/4"	1/4"
150	10	8121.1	178	126	168	466	775	170	160	30	1/4"	1/4"
200	10	14449	184	126	199	565	940	215	200	30	3/8"	3/8"
250	10	22591	225	197	234	626	1140	270	250	40	3/8"	1/2"
300	10	32569	257	197	272	739	1290	382	300	45	1/2"	1/2"
350	10	44419	257	350	297	842	1485	444	350	45	1/2"	1/2"
400	10	58040	279	350	330	933	1650	508	400	50	1/2"	3/4"
450	10	73382	311	350	355	1019	1805	552	450	50	3/4"	3/4"
500	10	90869	359	380	391	1156	2000	612	500	50	3/4"	3/4"
600	10	131156	372	400	461	1338	2200	772	585	60	1"	1"
700	6	107739	378	400	534	1425	2385	772	635	60	1"	1"

(*) → For lower working pressures see Ø cylinder.

Table 9



KNIFE GATE VALVES

GA SERIES

SINGLE-ACTING PNEUMATIC CYLINDER

- The air supply pressure to the cylinder is a minimum of 6 Kg/cm² and a maximum of 10 Kg/cm²; the air must be dry and lubricated.
- Available for opening or closing in case of air supply failure (spring opening or closing).
- The casing is made of aluminium, the covers of nodular cast iron or carbon steel, the rod of AISI304, the piston of rubber-coated steel, the O-ring seals of nitrile and the spring is made of steel.
- The **actuator design is spring activated** for valves with diameters **up to DN200**. For larger diameters the actuator contains a double-acting cylinder and an air tank which stores the volume of air necessary to carry out the last movement in the event of an air supply failure.
- **B = max width** of the valve (no actuator).
D = max height of the valve (no actuator).
- Available: DN50 to DN200, other DN to order.
- Please see the "CMO Pneumatic Actuators" catalogue if you require further information.

fig. 20

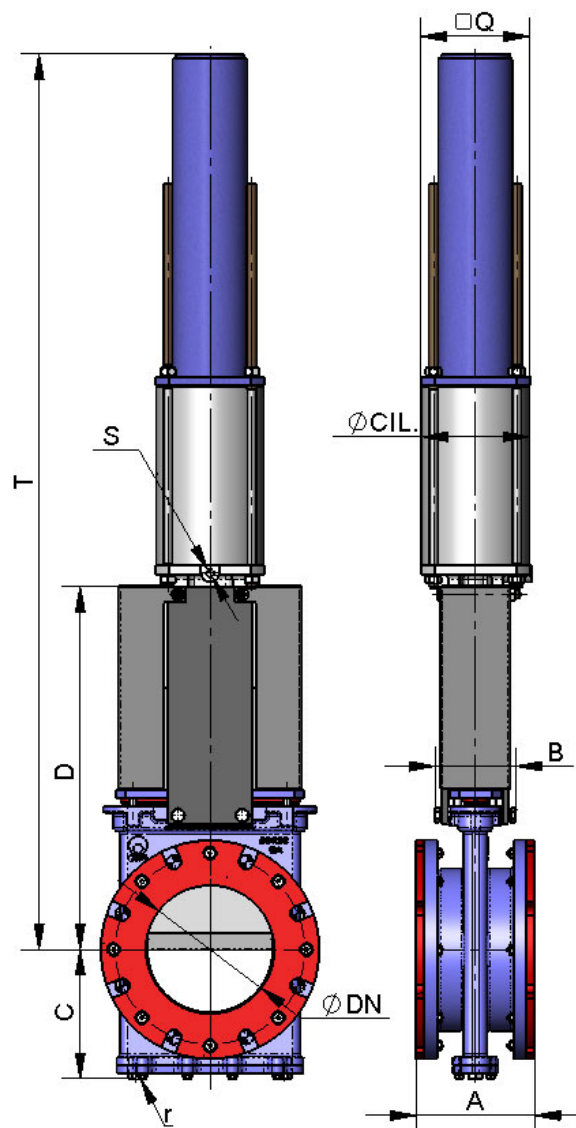

DN	ΔP (Kg/cm ²)	DRAFT (Nw)	A	B	C	D	T	Q	Ø CYL.	Ø ROD	S (B.S.P.)	r (B.S.P.)
50	10	905.21	175	109	106	280	752	110	125	25	1/4"	1/4"
65	10	1506.9	175	109	113	306	794	110	125	25	1/4"	1/4"
80	10	2312.5	175	109	122	332	836	135	125	25	1/4"	1/4"
100	10	3609.8	175	109	136	368	906	170	160	30	1/4"	1/4"
125	10	5639.4	178	126	153	421	986	215	200	30	3/8"	1/4"
150	10	8121.1	178	126	168	466	1056	215	200	30	3/8"	1/4"
200	10	14449	184	126	199	565	1439	270	250	40	3/8"	3/8"

Table 10

KNIFE GATE VALVES

GA SERIES

ELECTRIC ACTUATOR

- This actuator is automatic and includes the following parts:
 - Electric motor.
 - Stem.
 - Yoke.
- Options:
 - Different types and makes.
 - Non-rising stem.
- ISO 5210 / DIN 3338 Flanges.
- Available: DN50 to DN1500, other DN to order.
- From DN350 (inclusive) the motor is geared.

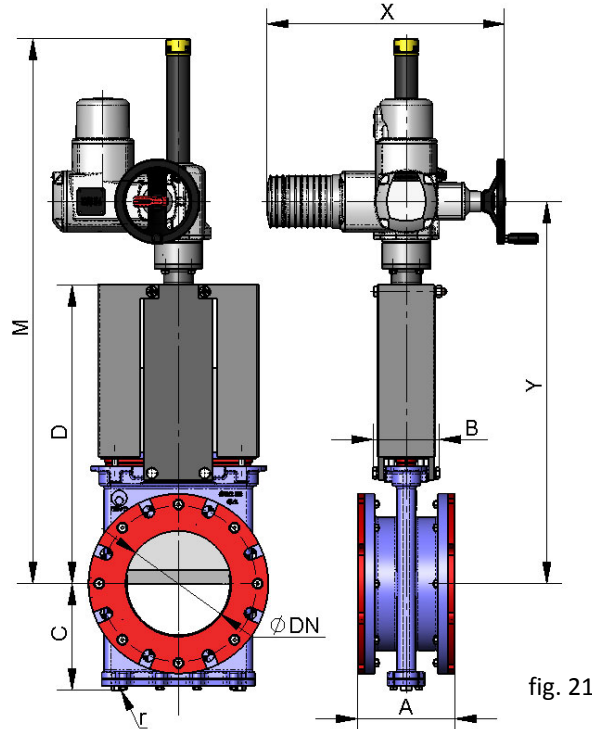

fig. 21

DN	ΔP (Kg/cm ²)	DRAFT (Nw)	TORQUE (Nm)	A	B	C	D	M	X	Y	r (B.S.P.)
50	10	905.21	2.06	175	109	106	280	631	451	418	1/4"
65	10	1506.9	3.48	175	109	113	306	683	451	470	1/4"
80	10	2312.5	5.28	175	109	122	332	719	451	506	1/4"
100	10	3609.8	8.24	175	109	136	368	775	451	559	1/4"
125	10	5639.4	16.1	178	126	153	421	819	451	604	1/4"
150	10	8121.1	23.18	178	126	168	466	1028	451	703	1/4"
200	10	14449	41.28	184	126	199	565	1116	474	766	3/8"
250	10	22591	64.54	225	197	234	626	1274	474	879	1/2"
300	10	32569	93.05	257	197	272	739	1377	631	1007	1/2"
350	10	44419	172.2	257	350	297	842	1570	631	1098	1/2"
400	10	58040	224.9	279	350	330	933	1661	631	1184	3/4"
450	10	73382	284.5	311	350	355	1019	1903	631	1321	3/4"
500	10	90869	496.8	359	380	391	1156	2185	701	1523	3/4"
600	10	131156	717.1	372	400	461	1338	2203	631	1515	1"
700	6	107739	589.1	378	400	534	1425	2428	631	1631	1"
750	6	129527	718	395	400	559	1520	2575	631	1727	1"
800	6	141228	772.2	411	400	584	1615	2723	631	1821	1"
900	6	179489	1164	470	400	649	1823	3083	631	2196	1"
1000	6	221406	1436	534	440	699	1992	3345	631	2295	1"
1100	6	269251	2021	534	440	730	2217	3670	631	2520	1 1/2"
1200	6	321856	2416	537	480	775	2351	3904	631	2654	1 1/2"
1300	6	377925	3175	537	480	805	2882	4550	631	3208	1 1/2"
1400	6	440582	3703	533	520	875	3250	5018	631	3576	1 1/2"
1500	2	176037	1322	533	520	925	3695	5530	631	4026	1 1/2"

Table 11



KNIFE GATE VALVES

GA SERIES

HYDRAULIC ACTUATOR (Oil pressure: 135 Kg/cm²)

- **B= max width** of the valve (no actuator).
D = max height of the valve (no actuator).
- The hydraulic actuator includes:
 - Hydraulic cylinder.
 - Yoke.
- Available: DN50 to DN1500.
- Different types and makes available according to customer's requirements.

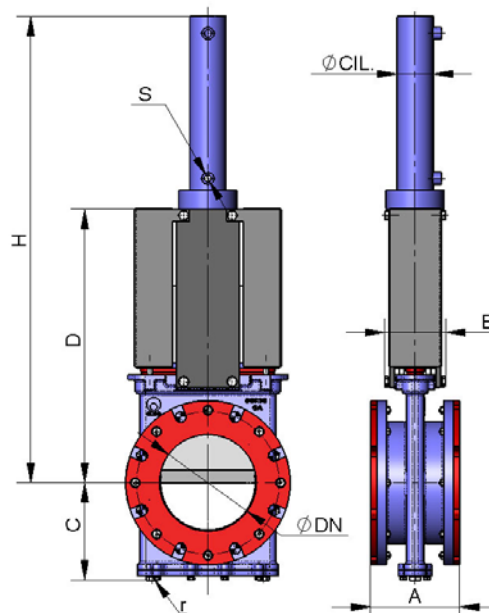

fig. 22

DN	ΔP (Kg/cm ²)	DRAFT (Nw)	A	B	C	D	H	Ø CYL.	Ø ROD	S (B.S.P.)	Cap. Oil (dm ³)	r (B.S.P.)
50	10	905.21	175	109	106	280	527	25	18	3/8"	0.04	1/4"
65	10	1506.9	175	109	113	306	610	25	18	3/8"	0.05	1/4"
80	10	2312.5	175	109	122	332	692	25	18	3/8"	0.05	1/4"
100	10	3609.8	175	109	136	368	770	32	22	3/8"	0.11	1/4"
125	10	5639.4	178	126	153	421	847	40	28	3/8"	0.19	1/4"
150	10	8121.1	178	126	168	466	1022	50	28	3/8"	0.36	1/4"
200	10	14449	184	126	199	565	1162	50	28	3/8"	0.47	3/8"
250	10	22591	225	197	234	626	1352	63	36	3/8"	0.91	1/2"
300	10	32569	257	197	272	739	1505	80	36	3/8"	1.73	1/2"
350	10	44419	257	350	297	842	1686	100	45	1/2"	3.1	1/2"
400	10	58040	279	350	330	933	1866	125	56	1/2"	5.55	3/4"
450	10	73382	311	350	355	1019	2066	125	56	1/2"	6.22	3/4"
500	10	90869	359	380	391	1156	2430	125	56	1/2"	6.99	3/4"
600	10	131156	372	400	461	1338	2161	160	70	1/2"	13.47	1"
700	6	107739	378	400	534	1425	2410	160	70	1/2"	15.68	1"
750	6	129527	395	400	559	1520	2576	160	70	1/2"	16.79	1"
800	6	141228	411	400	584	1615	2742	160	70	1/2"	17.89	1"
900	6	179489	470	400	649	1823	3053	200	90	1/2"	31.42	1"
1000	6	221406	534	400	699	1992	3322	200	90	1/2"	34.56	1"
1100	6	269251	534	440	730	2217	3685	220	90	1/2"	45.62	1 1/2"
1200	6	321856	537	480	775	2351	3919	220	90	1/2"	49.42	1 1/2"
1300	6	377925	537	480	805	2882	4565	250	90	1/2"	68.72	1 1/2"
1400	6	440582	533	520	875	3250	5035	250	90	1/2"	73.63	1 1/2"
1500	2	176037	533	520	925	3695	5545	200	90	1/2"	50.27	1 1/2"

Table 12

KNIFE GATE VALVES

GA SERIES

INFORMATION ON FLANGE DIMENSIONS

EN 1092-2 PN10

DN	ΔP (Kg/cm ²)	o	ϕd	P	ϕK
50	10	4	18	32	125
65	10	4	18	32	145
80	10	8	18	32	160
100	10	8	18	32	180
125	10	8	18	32	210
150	10	8	22	32	240
200	10	8	22	33	295
250	10	12	22	35	350
300	10	12	22	37	400
350	10	16	22	37	460
400	10	16	26	41	515
450	10	20	26	45	565
500	10	20	26	46	620
600	10	20	30	49	725
700	6	24	30	56	840
750	6	24	33	58	900
800	6	24	33	59	950
900	6	28	33	62	1050
1000	6	28	36	69	1160
1100	6	32	36	72	1270
1200	6	32	39	74	1380
1300	6	32	39	80	1490
1400	6	36	42	81	1590
1500	2	38	45	82	1705

Table 13

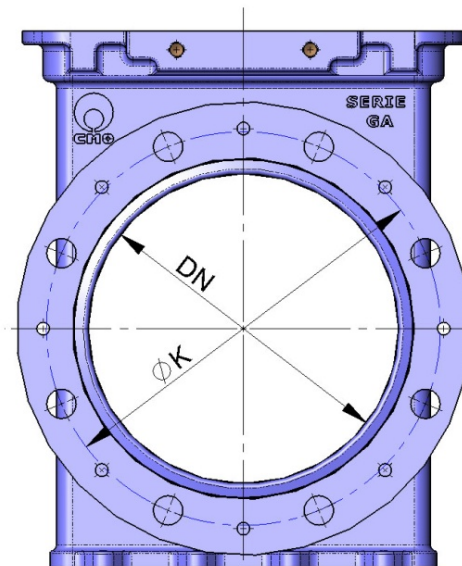

fig. 23

o THROUGH BOREHOLE

ANSI B16, class 150

DN	ΔP (Kg/cm ²)	o	R UNC	P	ϕK
2"	10	4	3/4"	1.28"	4.75"
2 1/2"	10	4	3/4"	1.28"	5.5"
3"	10	4	3/4"	1.28"	6"
4"	10	8	3/4"	1.28"	7.5"
5"	10	8	7/8"	1.28"	8.5"
6"	10	8	7/8"	1.28"	9.5"
8"	10	8	7/8"	1.32"	11.75"
10"	10	12	1"	1.4"	14.25"
12"	10	12	1"	1.48"	17"
14"	10	12	1 1/8"	1.48"	18.75"
16"	10	16	1 1/8"	1.64"	21.25"
18"	10	16	1 1/4"	1.8"	22.75"
20"	10	20	1 1/4"	1.84"	25"
24"	10	20	1 3/8"	1.96"	29.5"
28"	6	28	1 3/8"	2.24"	34"
30"	6	28	1 3/8"	2.32"	36"
32"	6	28	1 5/8"	2.36"	38.5"
36"	6	32	1 5/8"	2.48"	42.75"
40"	6	36	1 5/8"	2.76"	47.25"

Table 14

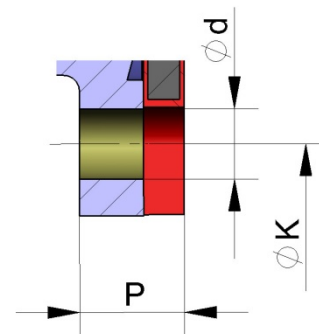
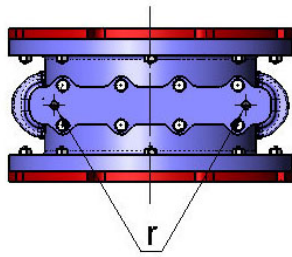

fig. 24

KNIFE GATE VALVES

GA SERIES



STANDARD VERSION

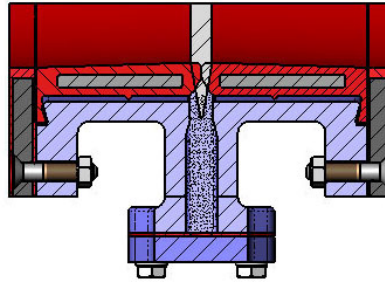

SECTION A-A

DN	r (B.S.P.)
50	1/4"
65	1/4"
80	1/4"
100	1/4"
125	1/4"
150	1/4"
200	3/8"
250	1/2"
300	1/2"
350	1/2"
400	3/4"
450	3/4"
500	3/4"
600	1"

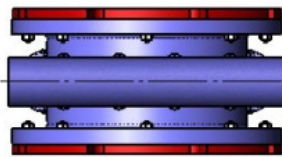
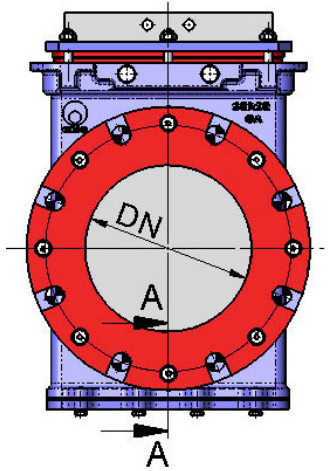

OPTION 1

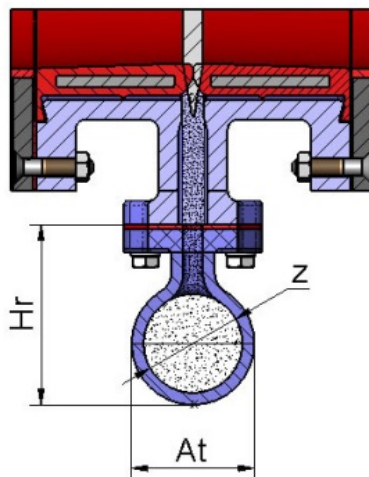

SECTION B-B

DN	Ht	Lt	At	Hr	z (B.S.P.)
50	158	185	42	68	1"
65	168	200	42	68	1"
80	174	220	42	68	1"
100	188	240	42	68	1"
125	208	265	42	73	1"
150	223	290	42	73	1"
200	272	350	62	93	1 3/4"
250	310	400	62	98	1 3/4"
300	348	450	62	98	1 3/4"
350	373	520	62	98	1 3/4"
400	403	560	62	98	1 3/4"
450	428	610	62	98	1 3/4"
500	472	690	70	107	2"
600	542	790	70	107	2"

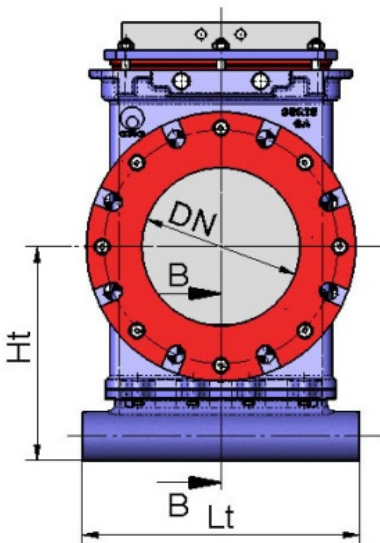



KNIFE GATE VALVES

GA SERIES

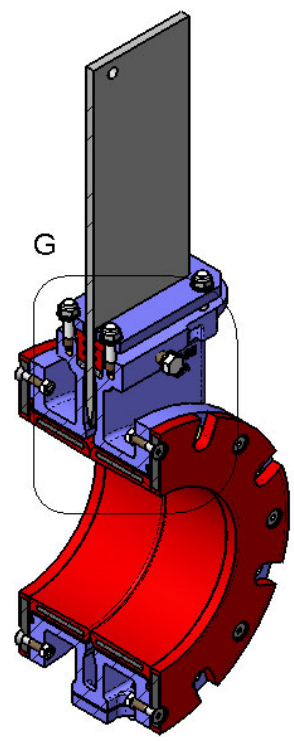
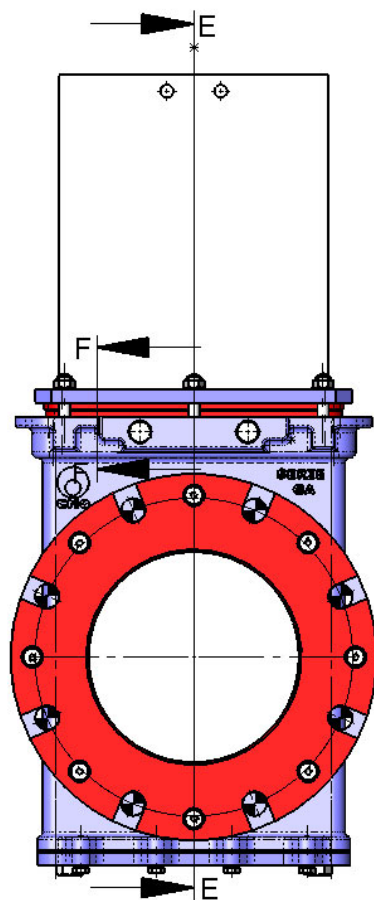

SECTION E-E

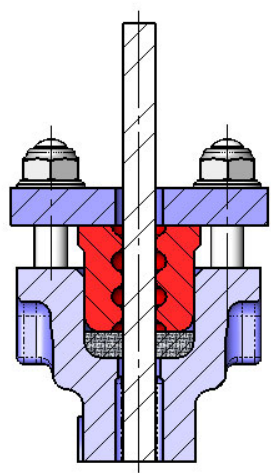

SECTION F-F

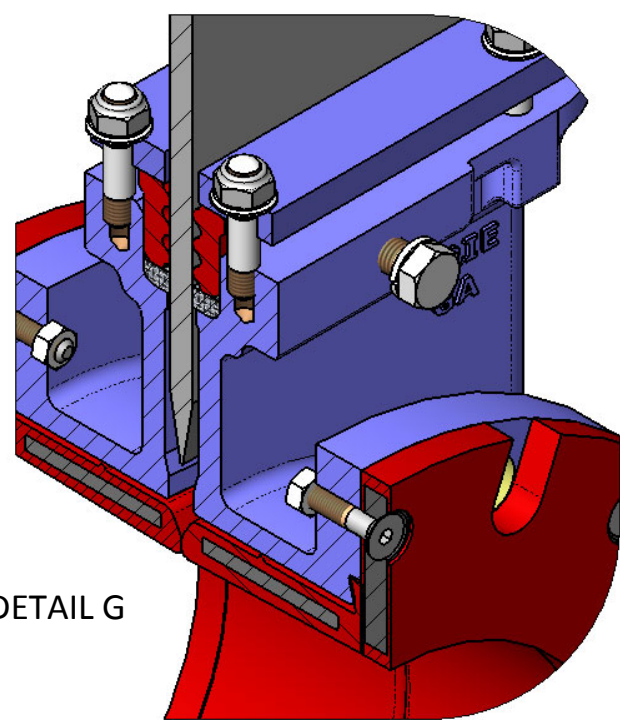

DETAIL G