



KNIFE-GATE VALVES

GH SERIES

05/10/2012

BIDIRECTIONAL WAFER Knife Gate Valve

- Bidirectional wafer-design knife gate valve.
- "Monoblock" one-piece cast iron body.
- Stainless steel gate. Two rubber sleeves.
- Provides high flow rates with low pressure drop.
- Various seat materials available.
- Face-to-face dimension in accordance with CMO standard.

General Applications:

-This knife gate valve is suitable for working in the mining industry, in loaded fluid transport lines, such as: water with stones, sludge, etc. and in general it is used for abrasive fluids in the chemical industry and waster water. Designed for the following applications:

- Mining
- Sewage treatment
- Electrical power stations
- Chemical plants
- Energy Sector
- Thermal power stations

Sizes: ND80-3" to ND900-36" (larger sizes on request).

Working (ΔP):

	Maximum PN
ND80-3" to ND900-36"	21 kg/cm ² = 300 psi

- The pressures indicated in the table, can be used in either of the valve's two directions.

Flange drill hole: DIN PN25 & ANSI B16.5 (300 LB)

Other Common Flanges: JIS standard
Australian standard
British standard

Directives: Machinery Directive: **DIR 2006/42/EC (MACHINERY)**
Pressure Equipment Directive: **DIR 97/23/EC (PED) ART.3, P.3**
Potential Explosive Atmospheres Directive: **DIR 94/9/EC (ATEX) CAT.3 ZONE 2 and 22 GD** for further information on categories and zones please contact the CMO Technical-Commercial Dept.

Quality Dossier: -All valves are tested hydrostatically at CMO and material and test certificates can be provided.
-Body test = working pressure x 1.5.
-Seat test = working pressure x 1.1.

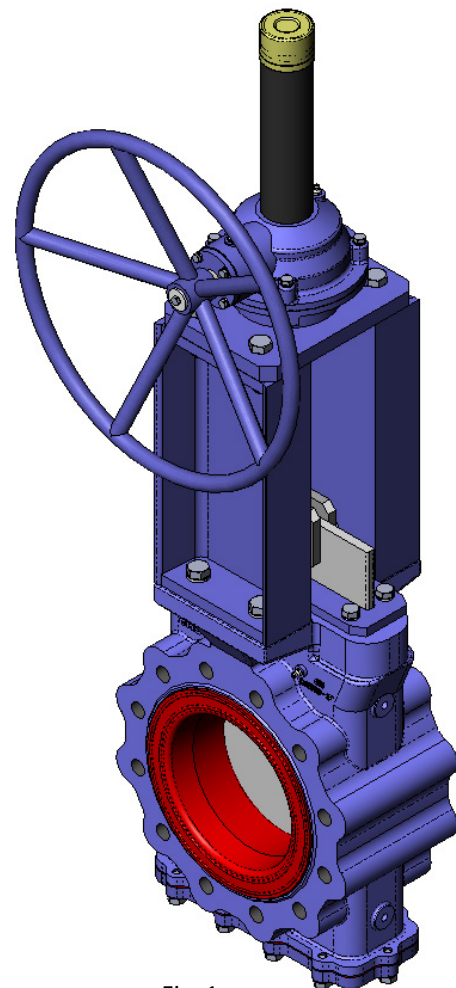

Fig. 1



KNIFE-GATE VALVES

GH SERIES

Advantages of CMO's "Model GH"

- This knife-gate valve's main characteristic is that it provides a full continuous flow. This means that in open position it produces no cavities and there are no turbulences in the fluid.
- The **GH** valve's body is composed of one single "monoblock" piece.
- The stem protection hood is independent from the handwheel securing nut, this means the hood can be disassembled without the need to release the handwheel. This advantage allows regular maintenance operations to be performed, such as lubricating the stem, etc.
- The stem on the CMO valve is made of 18/8 stainless steel. This is another added advantage, as some manufacturers produce it with 13% chrome and it gets rusty very quickly.
- The handwheel is made of GJS-500 nodular cast iron. Some manufacturers produce them in normal cast iron which can lead to breakages in the event of very high operating torque or knocks.
- The yoke is has a compact design with the bronze actuator nut protected in a sealed and lubricated box. This makes it possible to move the valve with a key, even without the handwheel (in other manufacturers' products this is not possible).
- The pneumatic actuator's upper and lower covers are made of GJS-500 nodular cast iron, making them highly shock resistant. This characteristic is essential in pneumatic actuators.
- The pneumatic cylinder's o-ring seals are commercial products and can be purchased worldwide. This means it is not necessary to contact CMO every time a seal is required.

STANDARD COMPONENTS LIST	
COMPONENT	WATERPROOF VERSION
1- Body	GJS-500
2- Gate	AISI304 / DUPLEX
3- Packing gland	STEEL
4- Packing seal.	NATURAL RUBBER
5- Packing	GREASED PACKING
6- Lower Cover	STEEL
7- Sleeve	NATURAL RUBBER
8- Support plates	STEEL
9- Stem	AISI303
10- Yoke	STEEL
11- Gear Box	---
12- Handwheel	STEEL
13- Hood	STEEL
14- Protec. cap	PLASTIC
15- Greaser (optional)	STEEL

Table 1

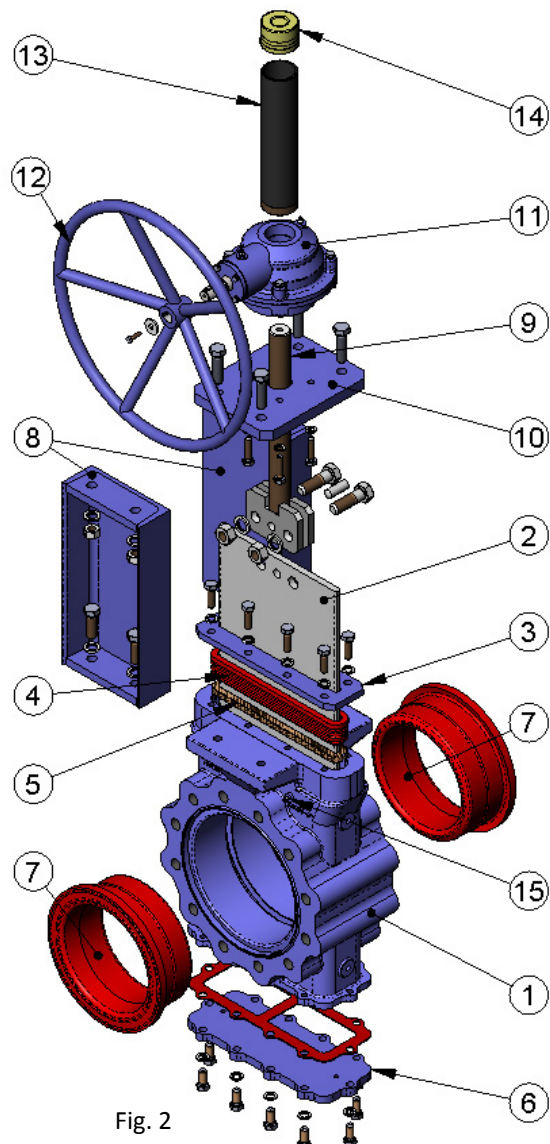

Fig. 2



KNIFE-GATE VALVES

GH SERIES

DESIGN CHARACTERISTICS

1- BODY (Fig. 3)

One-piece reinforced cast iron body.

The body provides a full continuous flow. This means that in open position it produces no cavities and, therefore, there are no turbulences in the fluid and the load loss is minimal.

Full port designed to provide high flow rates with low pressure drop.

The body's internal design prevents any build up of solids in the seat area.

The standard manufacturing material is GJS-500. Other materials such as: A216WCB carbon steel and stainless steel alloys (AISI316Ti, Duplex, 254SMO, Uranus B6, Ni-Resist, Ductile Ni-Resist, ...) are available on request. As standard, iron or carbon steel valves are painted with an anti-corrosive protection of 80 microns of EPOXY (colour RAL 5015). Other types of anti-corrosive protections are available on request.

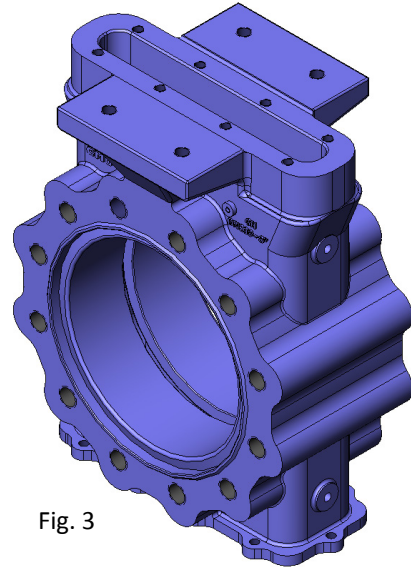

Fig. 3

2- GATE (Fig. 4)

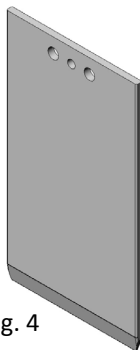

Fig. 4

The standard manufacturing materials are AISI304 for small dimensions valves, and DUPLEX or SUPERDUPLEX for bigger dimensions valves.

Other materials or combinations can be supplied on request.

The gate is polished on both sides to provide a smooth contact surface with the resilient seat. At the same time, the sharp edges on the gate are rounded to prevent the seal from being cut. There are different degrees of polishing, anti-abrasion treatments and various options to adapt the valves to the customer's requirements.

3- SEAT: (watertight)

The seat on the **GH** valve is composed of two rubber sleeves, located on either side of the body symmetrically. The sleeves are made of natural rubber with a metal core which helps to keep their shape and at the same time prevents deformations. Whilst the valve is in open position, the sleeves' elasticity ensures they are joined together permanently, preventing the accumulation of solids between the two parts of the body.

The **GH** valve is designed for abrasive fluids, and therefore, the sleeves protect the entire surface of the body which would be exposed to the abrasive flow. Regarding the sleeves' maintenance, these can be replaced from outside of the valve, making operation easier. It is a seat with two symmetrical parts, below we show a diagram of the seat (fig. 5).

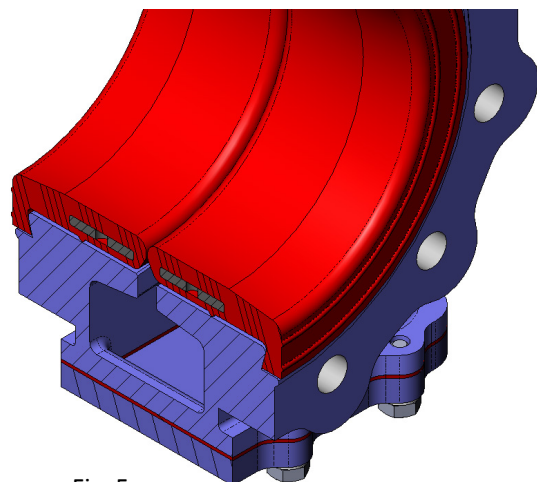

Fig. 5

KNIFE-GATE VALVES

GH SERIES

Resilient seat materials

NATURAL RUBBER

This is the standard resilient seat fitted on CMO GH model valves. It can be used in multiple applications at temperatures no higher than 90°C with abrasive products and it provides the valve with 100% watertight integrity. Application: fluids in general.

EPDM

Recommended for temperatures no higher than 90°C*, it provides the valve with 100% watertight integrity. Application: water and acids.

NITRILE

It is used in fluids containing fats or oils at temperatures no higher than 90°C*. It provides the valve with 100% watertight integrity.

VITON

Suitable for corrosive applications and continuous high temperatures of up to 190°C and peaks of 210°C. It provides the valve with 100% watertight integrity.

SEAT/SEALS		
Material	Max. T. (°C)	Applications
Natural rubber	90	General
EPDM (E)	90 *	Water, non-mineral acids and oils
Nitrile (N)	90 *	Hydrocarbons, oils and greases
Viton (V)	200	Hydrocarbons and solvents

Table 2

NOTE: More details and other materials available on request.

* → EPDM and nitrile: is possible until serving temperature Max.: 120°C under request.

4- PACKING

CMO's standard packing is composed of a specially designed EPDM O-ring which provides watertight integrity between the body and the gate, preventing any type of leakage to the atmosphere. It also has a greased packing strip to help the valve's operation during the opening and closing functions. They are located in an easily accessible place and can be replaced without dismantling the valve from the pipeline.

5- STEM

The stem on the CMO valve is made of 18/8 stainless steel. This characteristic provides high resistance and excellent corrosion-resistant properties.

The valve design is usually with rising stem. For that reason a stem hood is supplied to protect the stem from contact with dust and dirt, besides keeping it lubricated.

6- PACKING GLAND

The packing gland allows uniform force and pressure to be applied to the packing to ensure watertight integrity.

As standard, valves with steel body include steel packing glands.

7- ACTUATORS

All types of actuators can be supplied, with the advantage that the CMO design is fully interchangeable.

KNIFE-GATE VALVES

GH SERIES

This design allows the customer to change the actuators themselves and no extra assembly accessories are required. A design characteristic of CMO valves is that all actuators are interchangeable.

Manual:

- Handwheel with rising stem
- Chainwheel
- Gear Box
- Others (square nut,...)

Automatic:

- Electric actuator
- Pneumatic cylinder
- Hydraulic cylinder

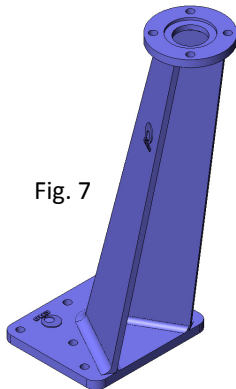
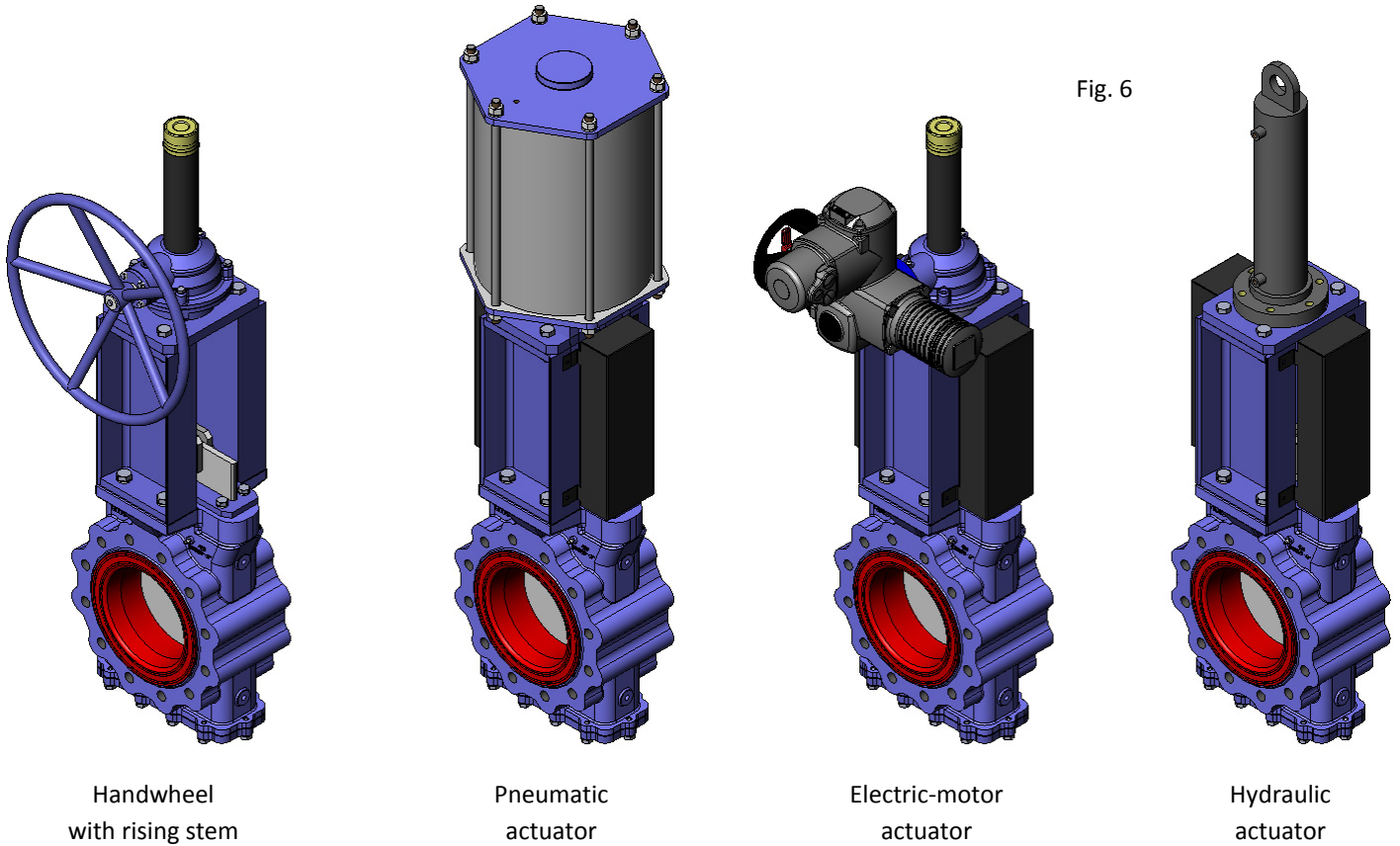

Wide Range of Accessories Available:

- Mechanical stops
- Locking devices
- Emergency manual actuators
- Solenoid valves
- Positioners
- Limit switches
- Proximity switches
- Straight floor stand (Fig. 8)
- Leaning floor stand (Fig. 7)

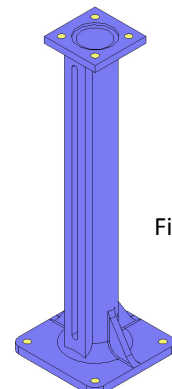

Stem extensions have also been developed, allowing the actuator to be located far away from the valve, to suit all needs. Please consult our technicians beforehand.

KNIFE-GATE VALVES

GH SERIES

ACCESSORIES AND OPTIONS

Different accessories are available to adapt the valve to specific working conditions such as:

- **Mirror Polished Gate:** The mirror polished gate is especially recommended in the food industry and, as standard, in applications in which solids can stick to the gate. It is an alternative to ensure the solids slide off and do not stick to the gate.
- **PTFE Lined Gate:** As with the mirror polished gate, it improves the valve's resistance to products that can stick to the gate.
- **Stellited Gate:** Stellite is added to the gate's internal circle to protect it from abrasion.
- **Scraper in the Packing:** Its function is to clean the gate during the opening movement and prevent possible damage to the packing.
- **Heating Jacket:** Recommended in applications in which the fluid can harden and solidify inside the valve's body. An external jacket keeps the body temperature constant, preventing the fluid from solidifying.
- **Flushing Holes in Body:** Several holes are drilled in the body to flush air, steam or other fluids out with the aim of cleaning the valve seat before sealing.
- **Solenoid valves** (Fig. 9): For air distribution to pneumatic actuators.
- **Connection boxes, wiring and pneumatic piping:** Units supplied fully assembled with all the necessary accessories.
- **Mechanical Limit Switches, Inductive Switches and Positioners:** Limit switches or inductive switches are installed to indicate precise valve position, as well as positioners to indicate continuous position (Fig. 9).
- **Connection boxes, wiring and pneumatic piping:** Units supplied fully assembled with all the necessary accessories.
- **Mechanical Locking Device:** Allows the valve to be mechanically locked in a set position for long periods.
- **Stroke Limiting Mechanical Stops:** They allow the stroke to be mechanically adjusted, limiting the valve's desired run.
- **Emergency manual actuator (hand wheel /gear box)** (Fig. 9): Allows manual operation of the valve in the event of power or air failure.
- **Interchangeable actuators:** All actuators are easily interchangeable.
- **Actuator or Yoke Support:** Made of EPOXY-coated steel, its robust design gives it great rigidity in order to resist the most adverse operation conditions.
- **Epoxy Coating:** All cast iron and carbon steel bodies and components on CMO valves are EPOXY coated, giving the valves great resistance to corrosion and an excellent finish. CMO's standard colour is blue, RAL-5015.
- **Gate Safety Protection:** In accordance with European Safety Standards ("EC" marking), CMO automated valves are equipped with gate guards, to prevent any objects from being accidentally caught in the gate.

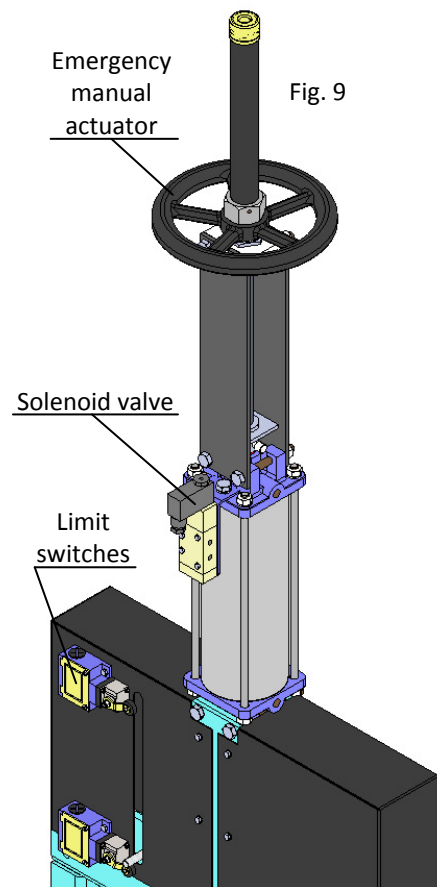



KNIFE-GATE VALVES

GH SERIES

TYPES OF EXTENSION

When the valve needs to be operated from a distance, the following different types of actuators can be fitted:

1 - Extension: Floor Stand.

This extension is performed by coupling a rod to the stem. By defining the length of the rod, the desired extension is achieved. A floor stand is normally installed to support the actuator.

The definition variables are as follows:

H1: Distance from the valve's shaft to the base of the stand.

d1: Separation from the wall to the end of the connecting flange.

Characteristics:

- It can be coupled to any type of actuator.
- A stem support-guide (Fig. 10) is recommended every 1.5 m.
- The standard floor stand is 800 mm high (Fig. 11). Other floor stand measurements available on request.
- A position indicator can be fitted to determine the valve's percentage of opening.
- Possibility of leaning floor stand (Fig. 12).

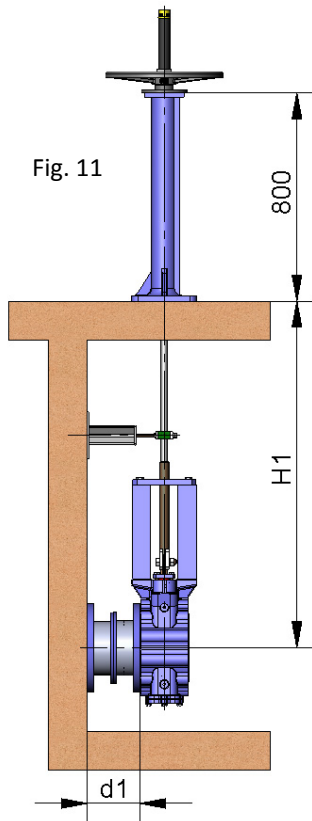

Fig. 11

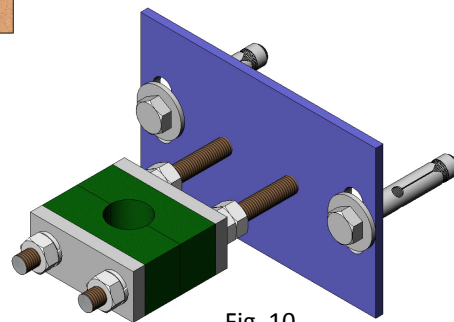

Fig. 10

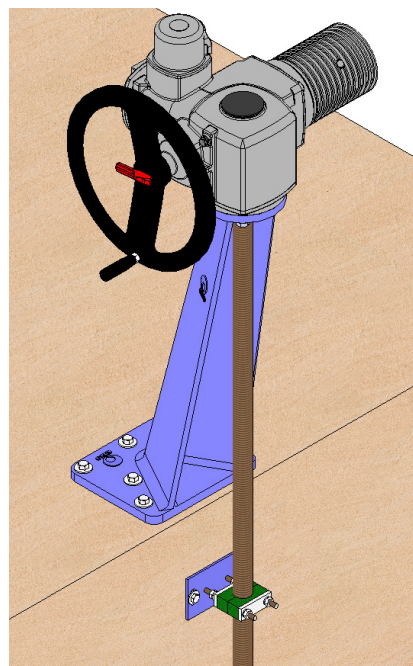

Fig. 12

COMPONENTS LIST	
Component	Standard Version
Stem	AISI 303
Rod	AISI 304
Support-guide	EPOXI coated carbon steel
Guide	Nylon
Stand	EPOXI coated GJS-500

Table 3



KNIFE-GATE VALVES

GH SERIES

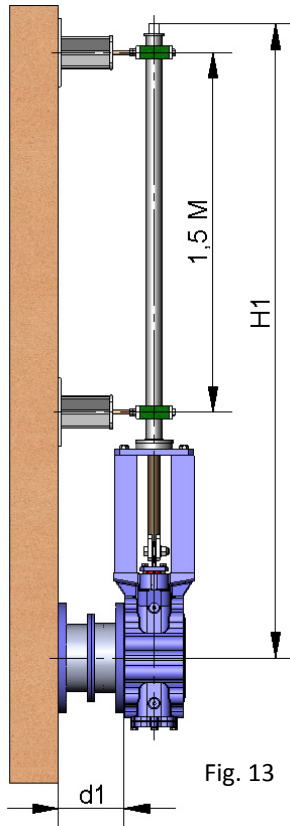

Fig. 13

2 - Extension: Pipe (Fig. 13)

Consists of raising the actuator. The pipe will rotate in the same direction as the handwheel when the valve is operated but it always remains at the same height.

The definition variables are as follows:

H1: Distance from the valve's shaft to the desired height of the actuator.

d1: Separation from the wall to the end of the connecting flange.

Characteristics:

- Standard actuators: Handwheel and "Square Nut"
- A pipe support-guide is recommended every 1.5 m.
- The standard materials are: EPOXY coated carbon steel or stainless steel.

3 - Extension: Extended Support Plates (Fig. 14)

When a short extension is required, it can be achieved by extending the support plates. An intermediate yoke can be fitted to reinforce the support plates' structure.

Fig. 14

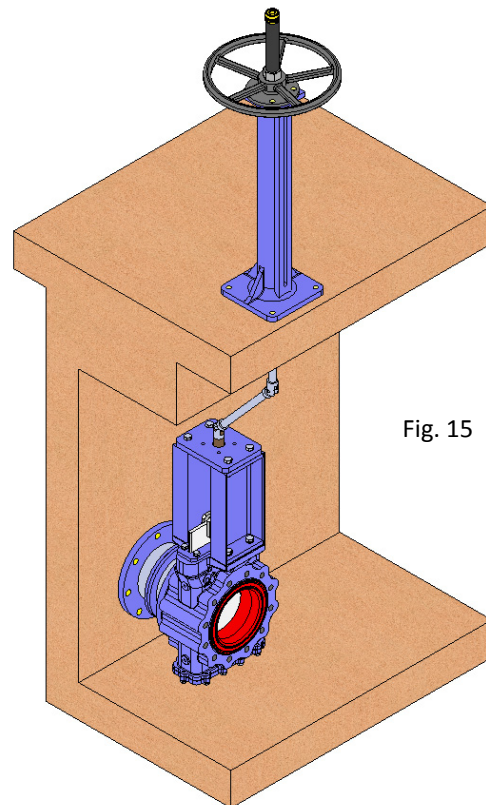
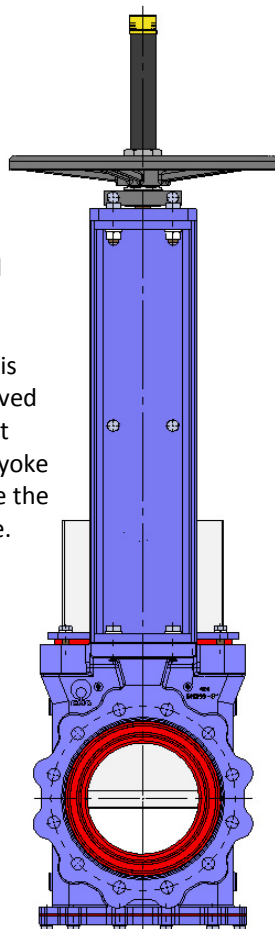

Fig. 15

4 - Extension: Universal Joint (Fig. 15)

If the valve and the actuator are not in correct alignment, the problem can be resolved by fitting a universal joint.



KNIFE-GATE VALVES

GH SERIES

INFORMATION ON FLANGE DIMENSIONS

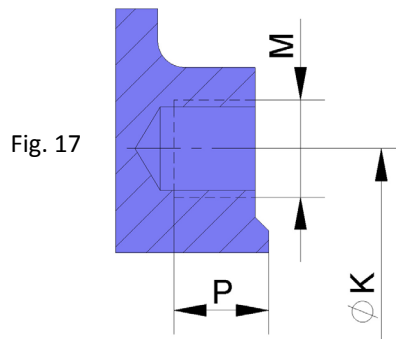
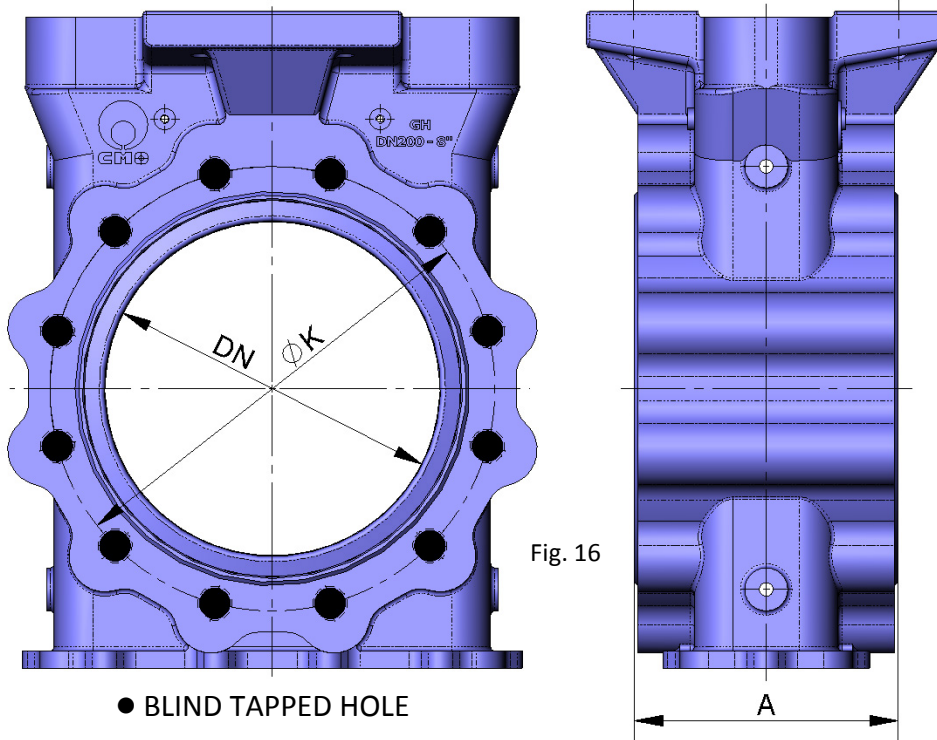

EN 1092-2 PN25						
DN	ΔP (Kg/cm ²)	A	•	Métric	P	ØK
80	21	176	8	M 16	20	160
100	21	181	8	M 20	23	190
150	21	184	8	M 24	27	250
200	21	184	12	M 24	32	310
250	21	226	12	M 27	35	370
300	21	242	16	M 27	35	430
350	21	252	16	M 30	38	490
400	21	287	16	M 33	43	550
450	21	311	20	M 33	48	600
500	21	373	20	M 33	55	660
600	21	362	20	M 36	55	770
750	21	413	--	--	--	--
900	21	467	28	M 45	60	1.090

Table 4

ANSI B16.5, class 300						
DN	ΔP (psi)	A	•	R UNC	P	ØK
3"	300	6,92"	8	3/4"	0,79"	6,63"
4"	300	7,13"	8	3/4"	0,91"	7,87"
6"	300	7,25"	12	3/4"	1,06"	10,63"
8"	300	7,25"	12	7/8"	1,26"	13"
10"	300	8,91"	16	1"	1,38"	15,25"
12"	300	9,54"	16	1 1/8"	1,38"	17,75"
14"	300	9,90"	20	1 1/8"	1,50"	20,25"
16"	300	11,29"	20	1 1/4"	1,69"	22,5"
18"	300	12,25"	24	1 1/4"	1,89"	24,75"
20"	300	14,69"	24	1 1/4"	2,17"	27"
24"	300	14,26"	24	1 1/2"	2,17"	32"
30"	300	16,26"	28	1 3/4"	2,17"	39,25"
36"	300	18,37"	32	2"	2,36"	46"

Table 5



KNIFE-GATE VALVES

GH SERIES

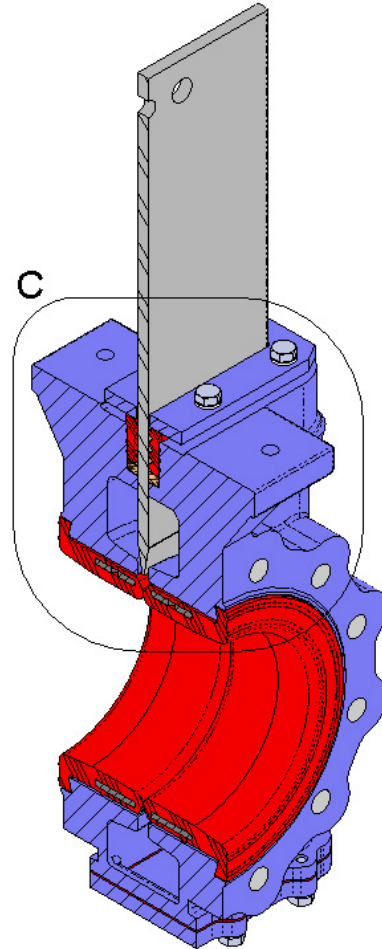
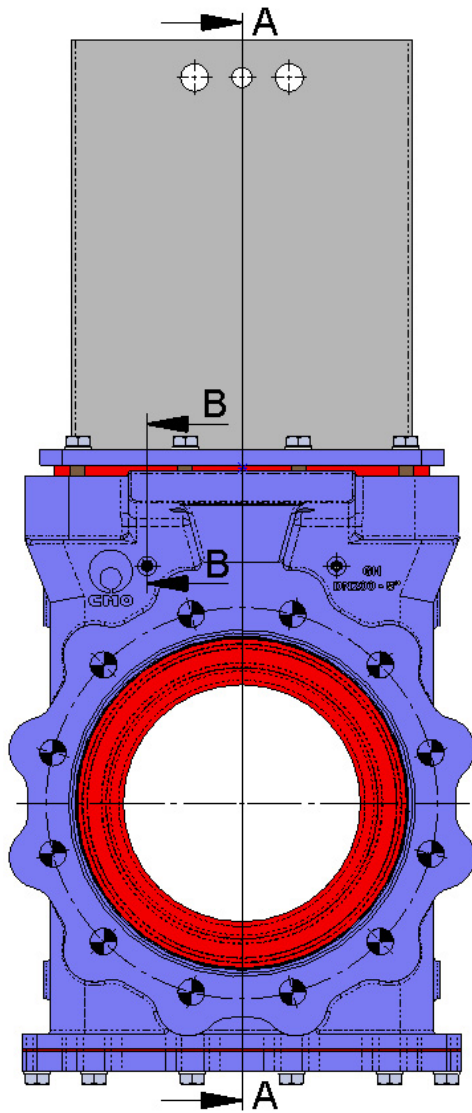

SECTION A-A

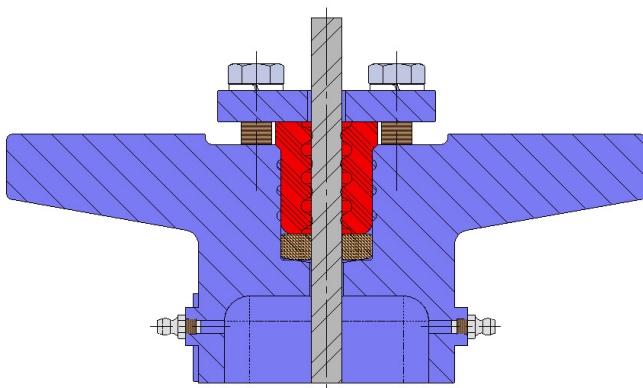

SECTION B-B

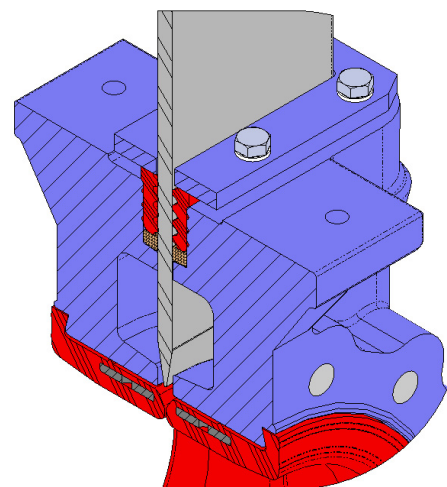

DETAIL C



KNIFE-GATE VALVES

GH SERIES

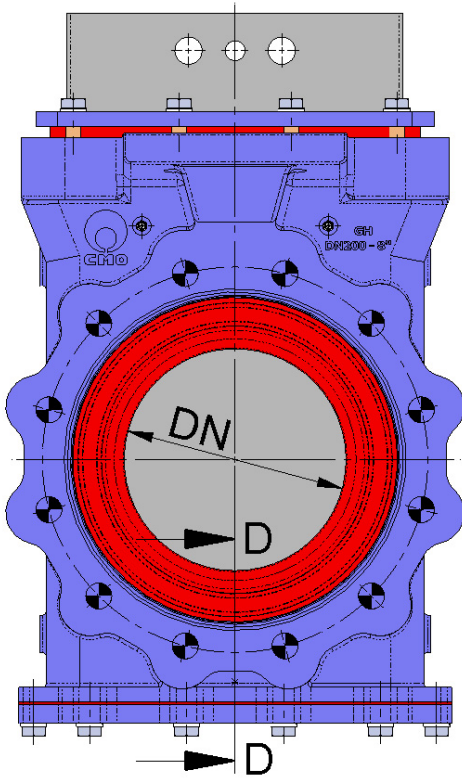

VERSION STANDARD

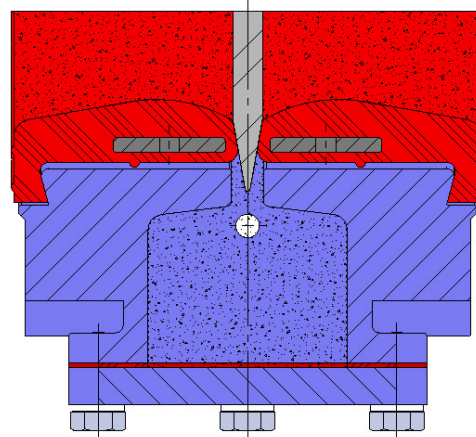

SECTION D-D

OPTION 1

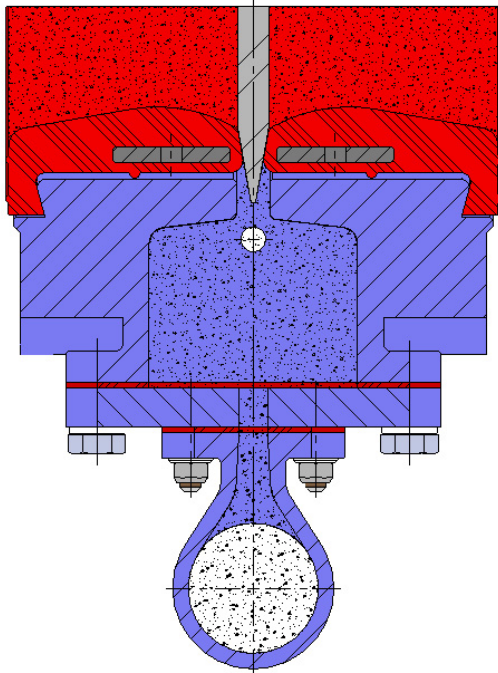

SECTION E-E

