

PLUG VALVES  
BALL VALVES  
GATE VALVES  
GLOBE VALVES  
CHECK VALVES  
BELLOWS SEAL VALVES

**ASME INDUSTRIAL VALVE**

**DIN INDUSTRIAL VALVE**

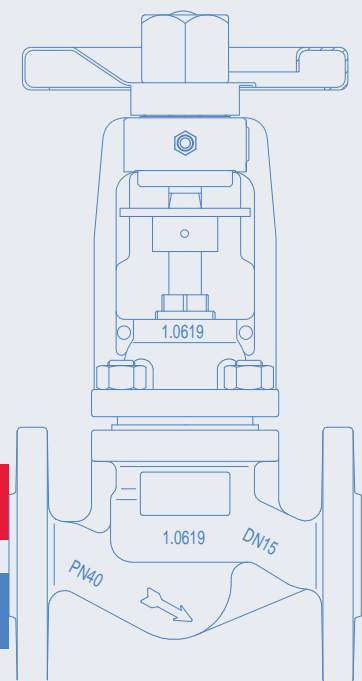

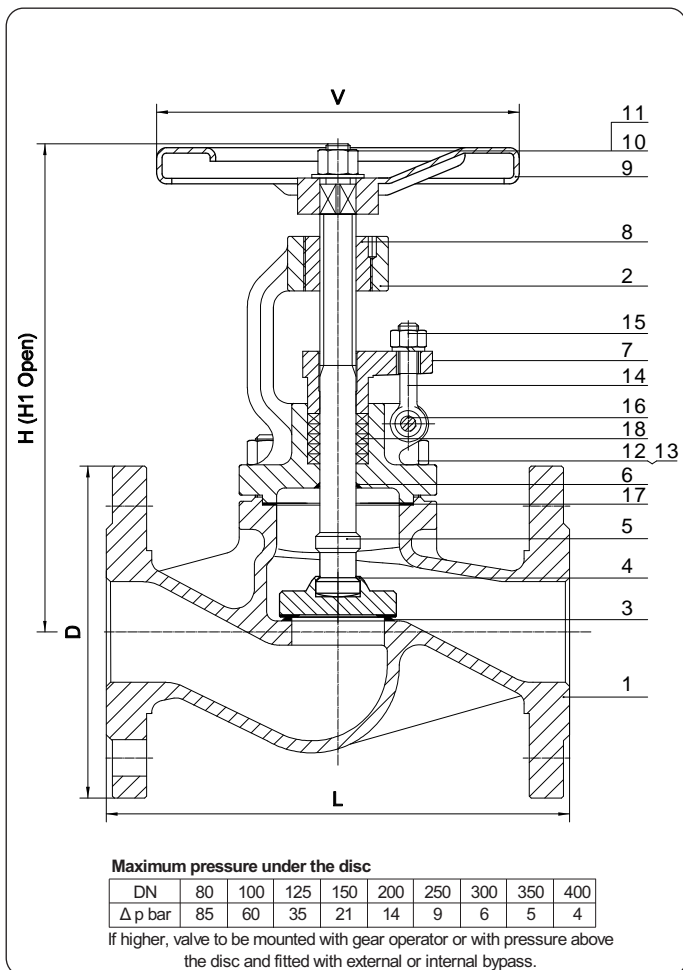

### standard features

- **Description** BOLTED BONNET  
OUTSIDE SCREW AND YOKE  
RISING STEM  
RISING HANDWHEEL  
LOOSE DISC
- **Design** DIN 3356
- **Face to face** DIN 3202
- **Flanges** DIN 2501  
DIN 2547  
DIN 2526 FORM E  
BW TO DIN 3239
- **Testing** DIN 3352 Part 1  
DIN 3230 Part 3
- **Rating** DIN 2401
- **Marking** EN 19  
CE - PED
- **Certificates** EN 10204 – 3.1 B

PART NAME		MATERIAL	
1	Body	1.0619	1.4581
2	Bonnet	1.0619	1.4581
3	Seat surface	X20Cr13(1) overlay	X5CrNiMo17-12-2 (1)
4	Disc seat surface	X20Cr13 (1)	X5CrNiMo17-12-2 (1)
5	Stem	X20Cr13 (2)	X5CrNiMo17-12-2 (2)
6	Back seat (integral)	1.0619 (B)	1.4581
7	Gland	1.0460	X5CrNiMo17-12-2
8	Yoke sleeve	GGG40.3(3)	Cu-Alloy (3)
9	Handwheel	Steel	Steel
10	Plate	1.0460	1.0460
11	Handwheel nut	1.0460	X5CrNiMo17-12-2
12	Bolts	CK35	A2-70
13	Nuts	C35	A2-70
14	Eye bolts	CK35	A2-70
15	Nuts	C35	A2-70
16	Eye bolt pin	CK35	A2-70
17	Gasket	S. S. reinforced graphite (4)	S. S. reinforced graphite
18	Packing	Graphite rings & wiper rings (4)	Graphite rings & wiper rings (4)

(1) On request: faced with Stellite® - Monel® - Hastelloy® - other materials

(2) On request: 17 Cr - Monel® - Hastelloy® - other materials

(3) On request: GGG50

(4) On request: PTFE - other materials

All data, subject to technical changes, are only for information and not for official use.



ISO 9001-2008  
CERTIFIED



**TÜV Rheinland**  
AD 2000 Merkblatt W0  
APPROVED

**armakom**

ARMAKOM ul. Zmudzka 31 85-028 Bydgoszcz

tel +48 52 3456011

fax +48 52 3456021

www.armakom.pl info@armakom.pl

**FIG.S.150** GLOBE VALVES DIN PN16 - Face to Face F1

SIZE DN	15	20	25	32	40	50	65	80	100	125	150	200	250	300	350	400
L RF	130	150	160	180	200	230	290	310	350	400	480	600	730	850	980	1100
D	95	105	115	140	150	165	185	200	220	250	285	340	405	460	520	580
V	140	140	160	160	180	180	200	250	300	350	400	500	500	500	600	600
H	180	190	220	225	252	263	290	330	350	420	455	550	665	800	960	1060
H1	190	202	236	241	272	287	315	360	385	465	505	630	755	910	1080	1210

**FIG.S.151** GLOBE VALVES DIN PN25 - Face to Face F1

SIZE DN	15	20	25	32	40	50	65	80	100	125	150	200	250	300	350	400
L RF/BW	130	150	160	180	200	230	290	310	350	400	480	600	730	850	980	1100
D	95	105	115	140	150	165	185	200	235	270	300	360	425	485	555	620
V	140	140	160	160	180	180	200	250	300	350	400	500	500	500	600	600
H	180	190	220	225	252	263	290	330	350	420	455	550	665	800	960	1060
H1	190	202	236	241	272	287	315	360	385	465	505	630	755	910	1080	1210

**FIG.S.152** GLOBE VALVES DIN PN40 - Face to Face F1

SIZE DN	15	20	25	32	40	50	65	80	100	125	150	200	250	300	350	400
L RF/BW	130	150	160	180	200	230	290	310	350	400	480	600	730	850	980	1100
D	95	105	115	140	150	165	185	200	235	270	300	375	450	515	580	660
V	140	140	160	160	180	180	200	250	300	350	400	500	500	500	600	600
H	180	190	220	225	252	263	290	330	350	420	455	550	665	800	960	1060
H1	190	202	236	241	272	287	315	360	385	465	505	630	755	910	1080	1210

### features on request

- |                                                     |                                                      |
|-----------------------------------------------------|------------------------------------------------------|
| <input type="checkbox"/> TOP FLANGE TO ISO 5210     | <input type="checkbox"/> PTFE SOFT SEATS             |
| <input type="checkbox"/> GEAR OPERATOR              | <input type="checkbox"/> STEM PROTECTION / EXTENSION |
| <input type="checkbox"/> CHAIN WHEEL OPERATOR       | <input type="checkbox"/> REGULATING DISC             |
| <input type="checkbox"/> PNEUMATIC ACTUATOR         | <input type="checkbox"/> DOUBLE STAGE DISC           |
| <input type="checkbox"/> HYDRAULIC ACTUATOR         | <input type="checkbox"/> STOP CHECK DISC             |
| <input type="checkbox"/> ELECTRIC ACTUATOR          | <input type="checkbox"/> LIVE LOADED PACKING         |
| <input type="checkbox"/> POSITION INDICATOR         | <input type="checkbox"/> DRAIN PLUG                  |
| <input type="checkbox"/> LIMIT SWITCHES             | <input type="checkbox"/> BW ENDS                     |
| <input type="checkbox"/> LOCKING / INTERLOCK SYSTEM | <input type="checkbox"/> ANSI CONNECTIONS            |

All dimensions in mm (except where differently indicated)

All data, subject to technical changes, are only for information and not for official use.



ISO 9001-2008  
CERTIFIED



**TÜV Rheinland**  
AD 2000 Merkblatt W0  
APPROVED

**armakom**

ARMAKOM ul.Zmudzka 31 85-028 Bydgoszcz

tel +48 52 3456011

fax +48 52 3456021

www.armakom.pl info@armakom.pl